

COMPACT DIMENSION TABLES

FOR ASSY® SCREWS

HARDWOOD OR BEECHWOOD $\rho_K \geq 680 \text{ kg/m}^3$

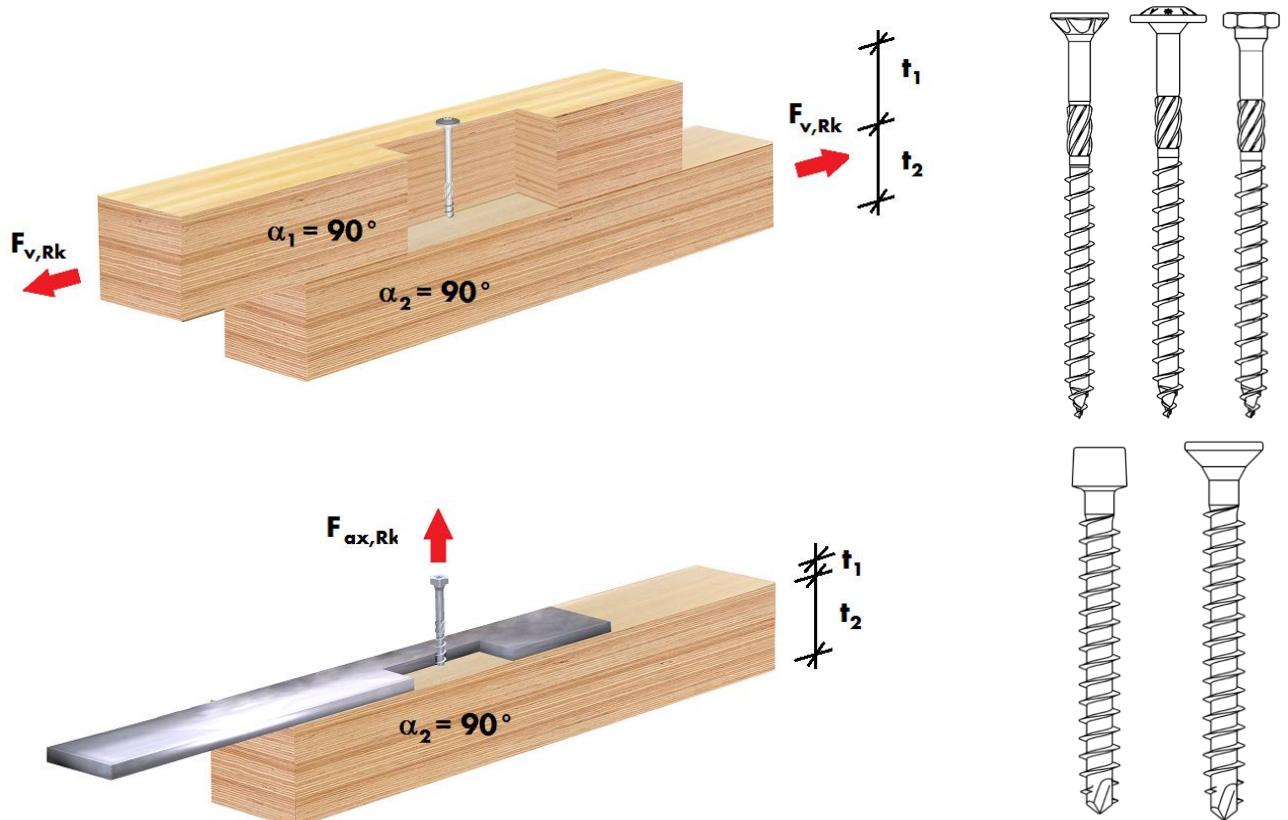

CONTENTS LOAD CAPACITY TABLES HARDWOOD/BEECHWOOD LAMINATED VENEER LUMBER

Determining the table values	Page	3
Hardwood-hardwood / Beechwood laminated veneer lumber- Beechwood laminated veneer lumber connections	Page	8
Using the table values	Page	9
Key and notes	Page	16
Shear capacity $F_{v,Rk}$ and $F_{v,Rd}$ 90-90°	Page	18
Shear capacity $F_{v,Rk}$ and $F_{v,Rd}$ 90-0°	Page	23
Withdrawal capacity $F_{ax,Rk}$ and $F_{ax,Rd}$ 90-90°	Page	28
Withdrawal capacity $F_{ax,Rk}$ and $F_{ax,Rd}$ 90-0°	Page	33
Lap shear capacity $F_{v,Rk}$ and $F_{v,Rd}$ 45°	Page	38
Withdrawal capacity $F_{ax,Rk}$ and $F_{ax,Rd}$ ASSY plus VG 90°	Page	40
Compression load capacity $k_c \times N_{pl,d}$ in kN with ASSY plus VG	Page	41
Main and supporting beam connection with ASSY plus VG	Page	42
Steel-hardwood/Beechwood laminated veneer lumber connections	Page	43
Using the table values	Page	44
Key and notes	Page	48
Shear capacity $F_{v,Rk}$ and $F_{v,Rd}$ 90°	Page	50
Shear capacity $F_{v,Rk}$ and $F_{v,Rd}$ 0°	Page	53
Withdrawal capacity $F_{ax,Rk}$ and $F_{ax,Rd}$ 90°	Page	56
Withdrawal capacity $F_{ax,Rk}$ and $F_{ax,Rd}$ 0°	Page	59
Lap shear capacity $F_{v,Rk}$ and $F_{v,Rd}$ 45°	Page	62
Lap shear capacity $F_{v,Rk}$ and $F_{v,Rd}$ with angle disc 45°	Page	63

Imprint

NOTE: These represent planning aids. The values are to be measured by authorized persons for a specific project.

DETERMINING TABLE VALUES FOR HARDWOOD/BEECHWOOD LVL/WOOD-WOOD

Boundary parameters

The tabulated values for load capacity were calculated pursuant to ETA-11/0190 and DIN EN 1995-1-1 for wood-wood and steel-wood connections with Würth ASSY screws in pre-drilled holes for wood with a characteristic density of $\rho_k = 680 \text{ kg/m}^3$. The characteristic values for load capacity and rated values for $k_{mod} = 0,8$.

Wood-wood / Steel-wood connections

The load capacity figures indicated correspond to the maximum load capacity that can be achieved with a screw of a specific diameter.⁽¹⁾ The required minimum screw length associated with each load capacity is indicated. The indicated load capacity for the respective wood density can be achieved using this or a longer screw length.

In all cases, the indicated load capacities also apply to screw lengths that are longer than the minimum screw length indicated l_{min} . For component thicknesses that are smaller than those listed in the table, the load capacity for a joint may be determined by a specific load capacity calculation.

⁽¹⁾ In the case of screw connections that run parallel to the grain, the screw length used for purposes of calculating the table values was limited as appropriate.

Rated value for load capacity

For modification factors $k_{mod} \neq 0,8$, the rated value for load capacity may be calculated based on the indicated characteristic load capacity:

$$F_{i,Rd} = F_{i,Rk} \times k_{mod} / \gamma_M$$

To be on the safe side, the tabulated rated value for load capacity may be used for all $k_{mod} \geq 0,8$.

Verification of screw load capacity for combined loads

Load capacity is verified pursuant to DIN EN 1995-1-1 (8.28).

$$\left(\frac{F_{ax,Ed}}{F_{ax,Rd}} \right)^2 + \left(\frac{F_{v,Ed}}{F_{v,Rd}} \right)^2 \leq 1$$

Joint using multiple screws

In the case of connections using multiple screws in a row in the direction of the wood grain, the effective number n_{ef} of the screws must be specified for screws in a row running in the direction of the wood grain.

Screws bearing a load in the axial direction (ETA-11/0190 A.1.3.1):

$n_{ef} = n^{0,9}$ $n_{ef} = \max \{ n^{0,9}; 0,9 * n \}$	<p>General case</p> <p>For screws that are arranged diagonally at $30^\circ \leq \alpha \leq 60^\circ$</p>
---	---

NOTE: These represent planning aids. The values are to be measured by authorized persons for a specific project.

DETERMINING TABLE VALUES FOR HARDWOOD/BEECHWOOD LVL/WOOD-WOOD

Screws subject to shear stress (DIN EN 1995-1-1 8.3.1.1 (8)):

- $n_{ef} = n$ if each of the screws arranged in a row parallel to the direction of the grain are shifted by $1 \cdot d$ at a right angle to the direction of the grain
- $n_{ef} = n^{kef}$ if the screws arranged in a row parallel to the direction of the grain are not shifted in their arrangement

a_1	$4 \cdot d$	$7 \cdot d$	$10 \cdot d$	$\geq 14 \cdot d$	Intermediate values of a_1 can be interpolated
k_{ef}	0,5	0,7	0,85	1,0	

Minimum screw spacing

The minimum spacing indicated in DIN EN 1995-1-1 Table 8.2 apply in the case of screws bearing a load in a right angle to the screw axis and/or in the axial direction:

- $a_1 \geq (4 + |\cos \alpha|) \times d$
- $a_2 \geq (3 + |\sin \alpha|) \times d$
- $a_{3,l} \geq (7 + 5 \times \cos \alpha) \times d$
- $a_{3,c} \geq 7 \times d$
- $a_{4,l} \geq (3 + 4 \times \sin \alpha) \times d$
- $a_{4,c} \geq 3 \times d$

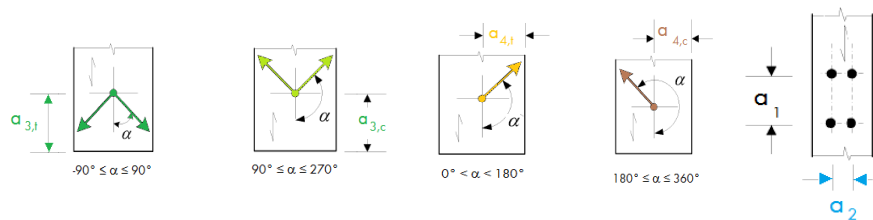

The minimum spacing a_1 and a_2 may be multiplied with the factor 0.7 in the case of sheet steel-wood connections.

In the case of screws that exclusively bear a load on the axial direction, the minimum spacing indicated in ETA-11/0190 apply based on the centre of gravity of the screw in the component:

- $a_1 = 5 d$
- $a_2 = 2,5 d$
- $a_{1,c} = 5 d$
- $a_{2,c} = 3 d$
- $a_1 \times a_2 = 25 d^2$

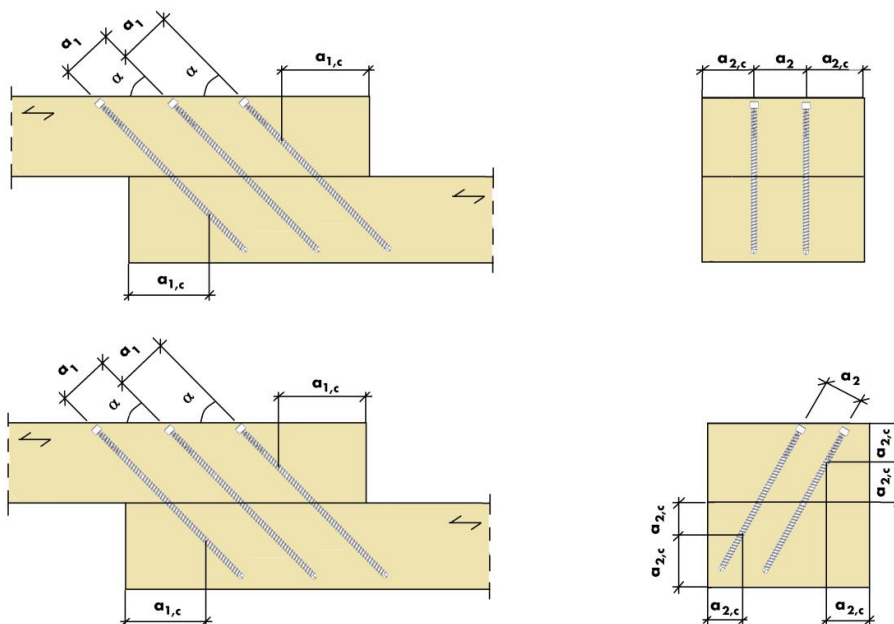

NOTE: These represent planning aids. The values are to be measured by authorized persons for a specific project.

DETERMINING TABLE VALUES FOR HARDWOOD/BEECHWOOD LVL/WOOD-WOOD

Example of a screw load capacity calculation

Wood-wood connection with Würth ASSY 3.0 SK 8x180 mm screws. The angle between the screw axis and the direction of the grain is 90° for both components ($\alpha_1 = 0^\circ$, $\alpha_2 = 0^\circ$) and the density of the face-end component is $t_1 = 120$ mm. A $k_{mod} = 0,8$ (NKL 1 and KLED "mean") is estimated for the rated load capacity value.

Component 1 Thickness = 120 mm
Wood $\rho_{k,1} = 680 \text{ kg/m}^3$
Pre-drilled $\alpha_1 = 90^\circ$
 $t_1 = 120 \text{ mm}$

Component 2 Thickness = 320 mm
Wood $\rho_{k,2} = 680 \text{ kg/m}^3$
Pre-drilled $\alpha_2 = 90^\circ$
 $t_2 = 60 \text{ mm}$

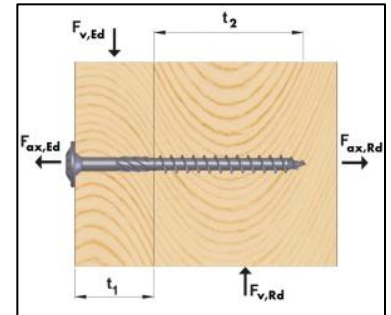

Würth ASSY 3.0 SK partial thread Ø8x180mm

d	= 8 mm	"Screw diameter"
l_g	= 80 mm	"Thread length"
d_h	= 22 mm	"Head diameter"
$M_{y,Rk}$	= 20000 Nmm	"Characteristic yield moment [Annex 1 Table 1.1]"
$f_{ax,k}$	= 11 N/mm ²	"Characteristic withdrawal parameter [A.1.3.1]"
$f_{head,k}$	= 10 N/mm ²	"Characteristic head pull-through parameter [A.1.3.2]"
f_{tens}	= 20 kN	"Characteristic tensile load capacity [Annex 1 Table 1.1]"

Data per ETA-11/0190 and corresponding product information

Screw head pull-through capacity

$$f_{head,k} = n_{ef} \cdot f_{head,k} \cdot d_h^2 \cdot (\rho_k / 350)^{0,8} \quad \text{"DIN EN 1995-1-1 (8.40b)"} \\ 1,0 \cdot 10 \cdot 22^2 \cdot (590 / 350)^{0,8} \\ 7.35 \text{ kN}$$

$$n_{ef} = 1,0 \quad \text{"Effective number of screws [A.1.3.1]"} \\ \rho_k = \min \{ \rho_{1,k}; 590 \} \quad \text{"The characteristic density is limited to 590 kg/m}^3 \text{ (axial load) [A.1.3.2]"} \\ \min \{ 680; 590 \} = 590 \text{ kg/m}^3$$

Load capacity of a screw when being pulled out

$$F_{ax,\alpha,Rk} = n_{ef} \times k_{ax} \times f_{ax,k} \times d \times l_{ef} \times (\rho_k/350)^{0,8} \quad \text{"[A1.3.1 (1.5)]"} \\ 1,0 \times 1,0 \times 11 \times 8 \times 60 \times (590 / 350)^{0,8} \\ 8.02 \text{ kN}$$

$$k_{ax} = 1,0 \\ \rho_k = \min \{ \rho_{2,k}; 590 \} \quad \text{"The characteristic density is limited to 590 kg/m}^3 \text{ [A.1.3.2]"} \\ \min \{ 680; 590 \} = 590 \text{ kg/m}^3 \\ l_{ef} = \min \{ l_g; t_2 \} \quad \text{"Anchorage length of the threads in component 2"} \\ \min \{ 80; 60 \} = 60 \text{ mm}$$

NOTE: These represent planning aids. The values are to be measured by authorized persons for a specific project.

DETERMINING TABLE VALUES FOR HARDWOOD/BEECHWOOD LVL/WOOD-WOOD

Screw tensile load capacity

$$F_{\text{tens,Rk}} = n_{\text{ef}} \cdot f_{\text{tens,k}} \quad \text{"DIN EN 1995-1-1 (8.40c)"} \\ = 1,0 \cdot 20 \\ = 20 \text{ kN}$$

Screw axial load capacity

$$F_{\text{ax,Rk}} = \min \{ F_{\text{head,Rk}}; F_{\text{ax,a,Rk}}; F_{\text{tens,Rk}} \} \\ = \min \{ 7,35; 8,02; 20 \}$$

$$F_{\text{ax,Rd}} = \min \{ \mathbf{F_{\text{head,Rk}} \times k_{\text{mod}} / \gamma_M}; F_{\text{ax,a,Rk}} \cdot k_{\text{mod}} / \gamma_M; F_{\text{tens,Rk}} / \gamma_M \} \\ = \min \{ \mathbf{7,35 \times 0,8 / 1,3}; 8,02 \cdot 0,8 / 1,3; 20 / 1,3 \} = 4,52 \text{ kN}$$

$$k_{\text{mod}} = 0,8 \quad \text{"DIN EN 1995-1-1 3.1.3"} \\ \gamma_M = 1,3 \quad \text{"DIN EN 1995-1-1 2.4.1"}$$

Embedment strengths

$$f_{\text{h,1,k}} = \frac{0,082 \cdot \rho_k \cdot (1 - 0,01 \cdot d)}{2,5 \cdot \cos^2 \alpha + \sin^2 \alpha} \quad \text{"Embedment strength in component 1, [A.1.2.2 (1.2)]"} \\ = \frac{0,082 \cdot 680 \cdot (1 - 0,01 \cdot 8)}{2,5 \cdot \cos^2 90^\circ + \sin^2 90^\circ} \\ = 51,3 \text{ N/mm}^2$$

$$\alpha = 90^\circ \quad \text{"Angle between screw axis and direction of the grain"}$$

$$f_{\text{h,2,k}} = f_{\text{h,1,k}} = 51,3 \text{ N/mm}^2 \quad \text{"Embedment strength in component 2, [A.1.2.2 (1.2)]"}$$

$$\beta = f_{\text{h,2,k}} / f_{\text{h,1,k}} = 1,0 \quad \text{"DIN EN 1995-1-1 (8.8)"}$$

Screw load capacity for shear stress

Equations 8.6 a to f per DIN EN 1995-1-1

$$F_{\text{v,1,Rk}} = f_{\text{h,1,k}} \times t_1 \times d = 49,3 \text{ kN} \quad \text{(a)}$$

$$F_{\text{v,2,Rk}} = f_{\text{h,2,k}} \times t_2 \times d = 24,6 \text{ kN} \quad \text{(b)}$$

$$F_{\text{v,3,Rk}} = \frac{f_{\text{h,1,k}} \cdot t_1 \cdot d}{1 + \beta} \left[\sqrt{\beta + 2 \cdot \beta^2 \cdot \left[1 + \frac{t_2}{t_1} + \left(\frac{t_2}{t_1} \right)^2 \right]} + \beta^3 \cdot \left(\frac{t_2}{t_1} \right)^2 - \beta \cdot \left(1 + \frac{t_2}{t_1} \right) \right] + \frac{F_{\text{ax,Rk}}}{4} = 18,6 \text{ kN} \quad \text{(c)}$$

$$F_{\text{v,4,Rk}} = 1,05 \cdot \frac{f_{\text{h,1,k}} \cdot t_1 \cdot d}{2 + \beta} \left[\sqrt{2 \cdot \beta \cdot (1 + \beta) + \frac{4 \cdot \beta \cdot (2 + \beta) \cdot M_{\text{y,Rk}}}{f_{\text{h,1,k}} \cdot d \cdot t_1^2}} - \beta \right] + \frac{F_{\text{ax,Rk}}}{4} = 19,3 \text{ kN} \quad \text{(d)}$$

NOTE: These represent planning aids. The values are to be measured by authorized persons for a specific project.

DETERMINING TABLE VALUES FOR HARDWOOD/BEECHWOOD LVL/WOOD-WOOD

$$F_{v,5,Rk} = 1,05 \cdot \frac{f_{h,1,k} \cdot t_2 \cdot d}{1 + 2 \cdot \beta} \left[\sqrt{2 \cdot \beta^2 \cdot (1 + \beta) + \frac{4 \cdot \beta \cdot (1 + 2 \cdot \beta) \cdot M_{y,Rk}}{f_{h,1,k} \cdot d \cdot t_2^2}} - \beta \right] + \frac{F_{ax,Rk}}{4} = 10,8 \text{ kN} \quad (e)$$

$$F_{v,6,Rk} = 1,15 \cdot \sqrt{\frac{2 \cdot \beta}{1 + \beta}} \cdot \sqrt{2 \cdot M_{y,Rk} \cdot f_{h,1,k} \cdot d} + \frac{F_{ax,Rk}}{4} = 6,50 \text{ kN} \quad (f)$$

$$F_{v,Rk} = \min \{F_{v,i,Rk}\} = 6,50 \text{ kN}$$

$$F_{v,Rd} = F_{v,Rk} \cdot k_{mod} / \gamma_M = 6,50 \cdot 0,8 / 1,3 = 4,00 \text{ kN}$$

NOTE: These represent planning aids. The values are to be measured by authorized persons for a specific project.

AXIAL / SHEAR CAPACITY TABLE

FOR ASSY® SCREWS

HARDWOOD/BEECHWOOD LAMINATED VENEER LUMBER WOOD-WOOD

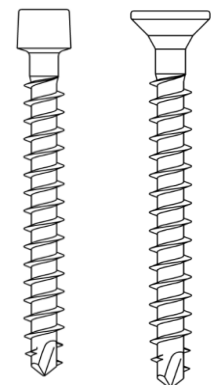
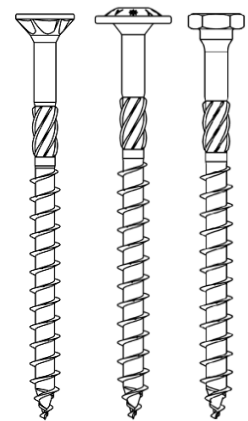
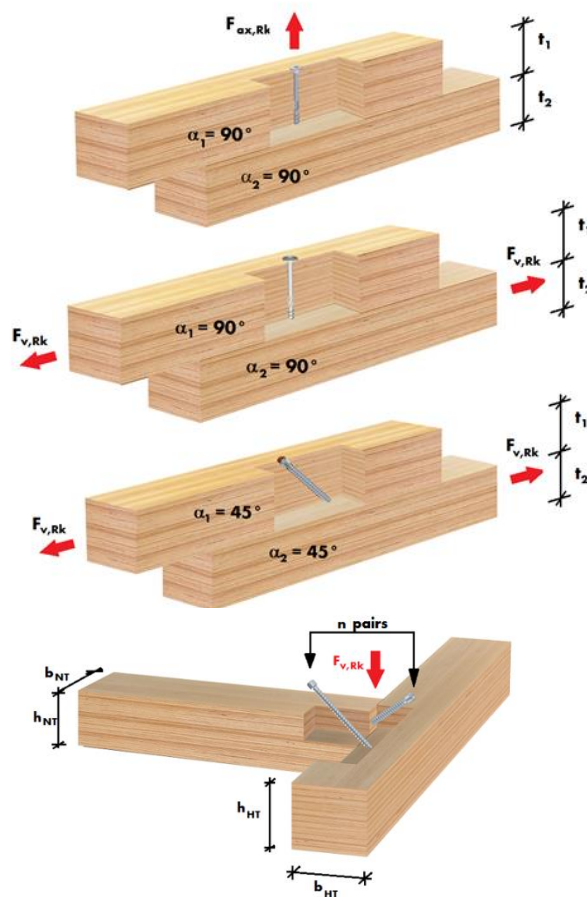

NOTE: These represent planning aids. The values are to be measured by authorized persons for a specific project.

USE FOR HARDWOOD/BEECHWOOD LAMINATED VENEER LUMBER/WOOD-WOOD

Sample calculation wood-wood

System: Connection purlin to binder
 Purlin: $b/h = 120 \text{ mm} / 240 \text{ mm}$, hardwood, ($\rho_k = 680 \text{ kg/m}^3$)
 Binder: $b/h = 160 \text{ mm} / 400 \text{ mm}$, hardwood, ($\rho_k = 680 \text{ kg/m}^3$)
 Calculation base: Measurement: EC5 or DIN EN 1995-1-1:2010-12 and national German application document DIN 20000-6:2012-06; ETA 11/0190 ASSY wood screws.
 Anchor force: $F_{v,Ed} = 3,2 \text{ kN}$ (NKL = 1, KLED = „mean“)
 $F_{ax,Ed} = 6,8 \text{ kN}$ (NKL = 1, KLED = „mean“)
 Prerequisite: Screw head flush with the top of the purlin: $t_1 = 240 \text{ mm}$

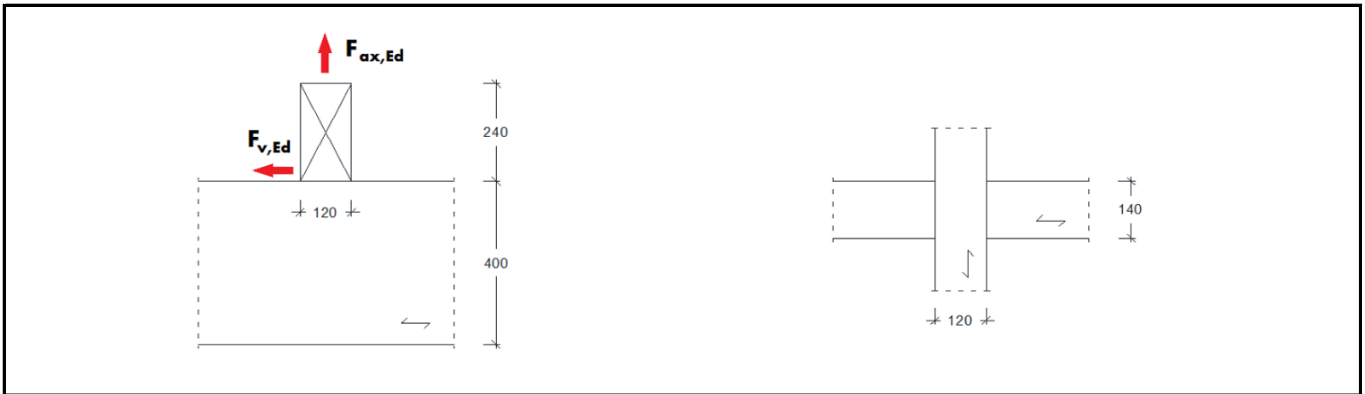

Alternative 1 - ASSY plus VG $\varnothing 8 \text{ mm}$

$F_{v,Ed} = 5,73 \text{ kN} \Rightarrow$ Table

Shear capacity hardwood/Beechwood laminated veneer lumber wood-wood $\alpha_1 = 90^\circ$, $\alpha_2 = 90^\circ$ - ASSY plus VG

Required minimum screw length $l_{min} = 380 \text{ mm}$

SHEAR CAPACITY HARDWOOD/BEECHWOOD LAMINATED VENEER LUMBER WOOD-WOOD
 $\alpha_1 = 90^\circ, \alpha_2 = 90^\circ$ - ASSY PLUS VG

ASSY plus VG - Shear capacity $F_{v,Rk}$ and $F_{v,Rd}$ ($k_{mod} = 0,8$) with required minimum screw

length l_{min}	$\varnothing 6\text{mm}$		$\varnothing 8\text{mm}$		$\varnothing 10\text{mm}$		$\varnothing 12\text{mm}$	
	$F_{v,Rk}$	l_{min}	$F_{v,Rk}$	l_{min}	$F_{v,Rk}$	l_{min}	$F_{v,Rk}$	l_{min}
30	3,60	90	4,66	120	7,82	180	11,7	240
	2,21	80	2,87	120	5,11	180	8,51	240
220	3,86	260	5,32	380	13,8	430	19,0	480
	2,37	260	5,73	380	8,51	430	11,7	480
240	3,86	260	5,32	380	13,8	430	19,0	480
	2,37	260	5,73	380	8,51	430	11,7	480
260	3,86	260	5,32	430	13,8	480	19,0	480
	2,37	260	5,73	430	8,51	480	11,7	480

$F_{v,Rk}$	l_{min}
kN	mm
5,73	380
F _{v,Rk}	F _{v,Rd}

$F_{ax,Ed} = 6,8 \text{ kN}$ (NKL = 1, KLED = „mean“)

NOTE: These represent planning aids. The values are to be measured by authorized persons for a specific project.

USE FOR HARDWOOD/BEECHWOOD LAMINATED VENEER LUMBER/WOOD-WOOD

$F_{ax,Ed} = 15,4 \text{ kN} \Rightarrow$ Table

Withdrawal capacity hardwood/Beechwood laminated veneer lumber wood-wood $\alpha_1 = 90^\circ, \alpha_2 = 90^\circ$ - ASSY plus VG

Required minimum screw length $l_{min} = 430 \text{ mm}$

WITHDRAWAL HARDWOOD/BEECHWOOD LAMINATED VENEER LUMBER WOOD-WOOD
 $\alpha_1 = 90^\circ, \alpha_2 = 90^\circ$ - ASSY PLUS VG

ASSY plus VG - Withdrawal capacity $F_{ax,Rk}$ and $F_{ax,Rd}$ ($k_{mod} = 0,8$) with required minimum screw length l_{min}

t_1 mm	Ø 6mm		Ø 8mm		Ø 10mm		Ø 12mm	
	$F_{ax,R}$ kN	l_{min} mm	$F_{ax,R}$ kN	l_{min} mm	$F_{ax,R}$ kN	l_{min} mm	$F_{ax,R}$ kN	l_{min} mm
30	3,14	80						
	1,93	80						
220	15,17	260	15,4	430	20,6	480	24,7	480
	2,58	260	20,0	430	32,0	480	43,7	480
240			15,4	430	22,4	480	26,9	480
			20,0	430	32,0	480	45,0	600

$F_{ax,R}$ kN	l_{min} mm
$F_{ax,Rk}$	
$F_{ax,Rd}$	

Selected: 1 x ASSY plus VG 8x430 mm

Minimum spacing:

Fulfilled

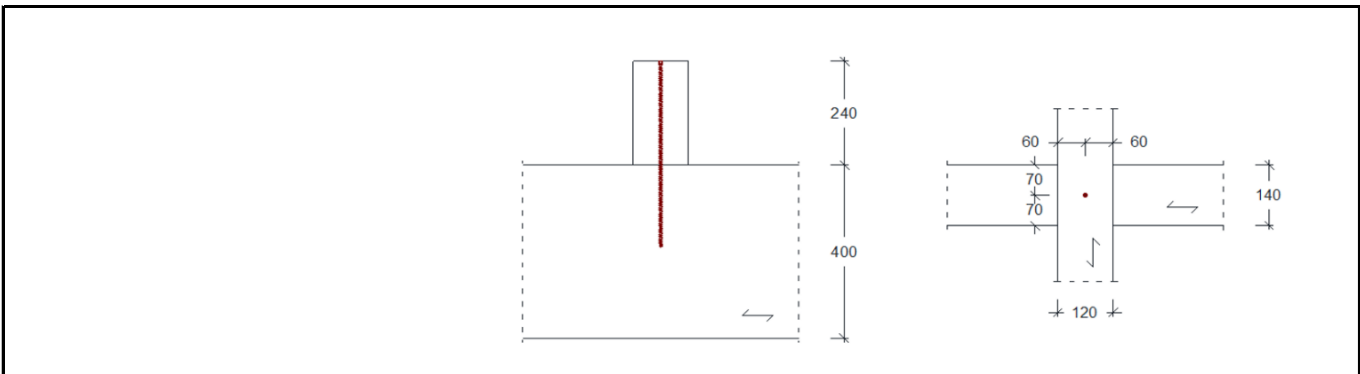

Effective number of screws:

$$n_{v,ef} = 1$$

$$n_{ax,ef} = 1$$

Verification of load capacity:

$$\left(\frac{F_{ax,Ed}}{n_{ax,ef} \cdot F_{ax,Rd}} \right)^2 + \left(\frac{F_{v,Ed}}{n_{v,ef} \cdot F_{v,Rd}} \right)^2 = \left(\frac{6,8}{1,0 \cdot 15,4} \right)^2 + \left(\frac{3,2}{1,0 \cdot 5,73} \right)^2 = 0,51 \leq 1$$

NOTE: These represent planning aids. The values are to be measured by authorized persons for a specific project.

USE FOR HARDWOOD/BEECHWOOD LAMINATED VENEER LUMBER/WOOD-WOOD

Alternative 2 - ASSY plus VG Ø 8 mm

$F_{v,Ed} = 4,00 \text{ kN} \Rightarrow$ Table

Shear capacity hardwood/Beechwood laminated veneer lumber wood-wood

$\alpha_1 = 90^\circ, \alpha_2 = 90^\circ$ - ASSY plus VG

Required minimum screw length $l_{min} = 300 \text{ mm}$

$F_{ax,Ed} = 4,52 \text{ kN} \Rightarrow$ Table

Withdrawal capacity hardwood/Beechwood laminated veneer lumber wood-wood

$\alpha_1 = 90^\circ, \alpha_2 = 90^\circ$ - ASSY plus VG

Required minimum screw length $l_{min} = 430 \text{ mm}$

Selected: 2 x ASSY plus VG 8x300 mm

Minimum spacing:

Fulfilled

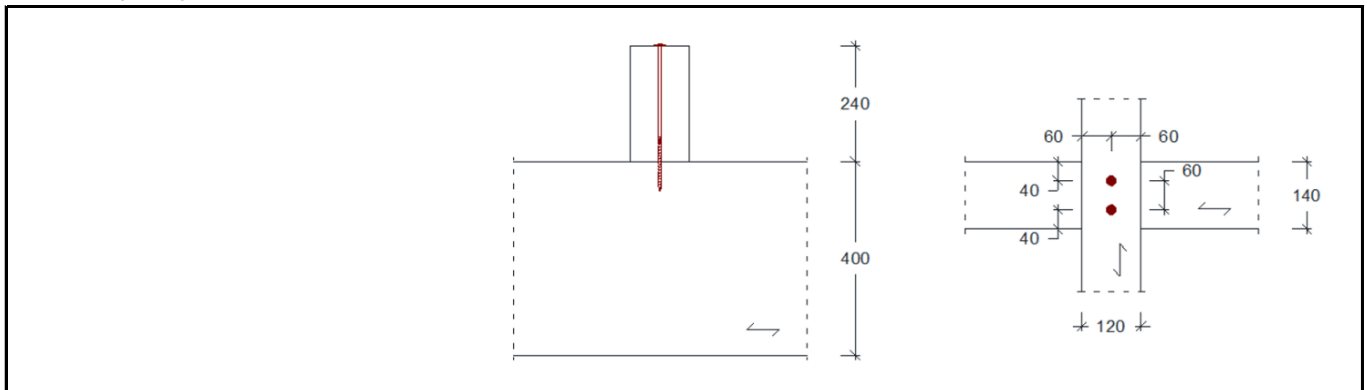

Effective number of screws:

$$n_{v,ef} = 2$$

$$n_{ax,ef} = 2^{0,9} = 1,87$$

Verification of load capacity:

$$\left(\frac{F_{ax,Ed}}{n_{ax,ef} \cdot F_{ax,Rd}} \right)^2 + \left(\frac{F_{v,Ed}}{n_{v,ef} \cdot F_{v,Rd}} \right)^2 = \left(\frac{6,8}{1,87 \cdot 4,52} \right)^2 + \left(\frac{3,2}{2,0 \cdot 4,00} \right)^2 = 0,81 \leq 1$$

Additional verification:

Transverse connection to the binder

USE OF HARDWOOD/BEECHWOOD LVL/WOOD-WOOD SHEAR CONNECTION

Sample calculation wood-wood; shear connection

System: 45° Shear connection wood to wood
 Side lumber: b/h = 80 mm / 360 mm, hardwood, ($\rho_k = 680 \text{ kg/m}^3$)
 Central lumber: b/h = 160 mm / 360 mm, hardwood, ($\rho_k = 680 \text{ kg/m}^3$)
 Calculation base: Measurement: EC5 or DIN EN 1995-1-1:2010-12 and national German application document DIN 20000-6:2012-06; ETA 11/0190 ASSY wood screws.
 Anchor force: $F_{Ed} = 640 \text{ kN}$ (NKL = 1, KLED = „mean“)
 Objective: Minimisation of required number of screws; small overlap area

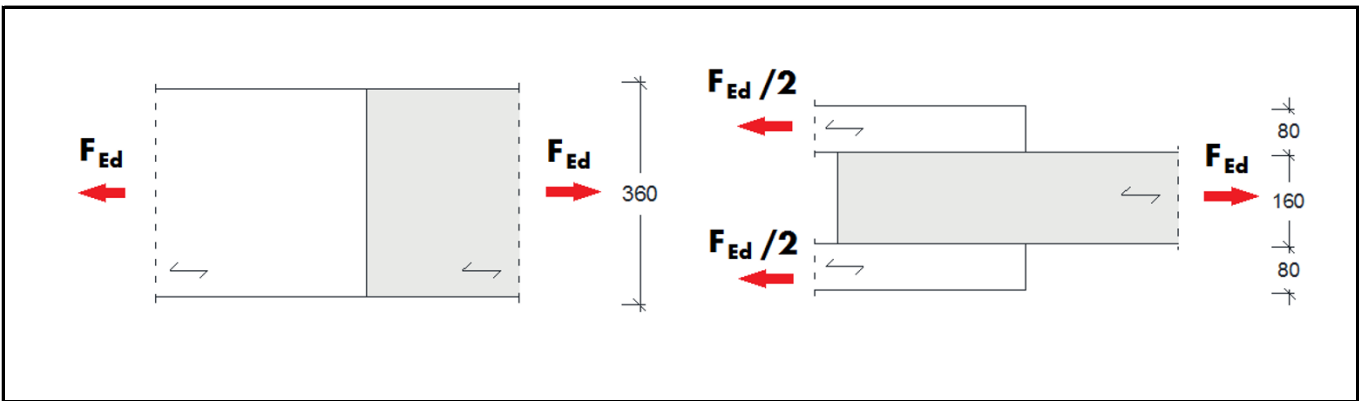

Alternative - ASSY plus VG

Lap shear hardwood/Beechwood laminated veneer lumber wood-wood
 $\alpha_1 = 45^\circ, \alpha_2 = 45^\circ$ - ASSY plus VG
 Side lumber thickness: $t_1 = 80 \text{ mm}$

LAP SHEAR HARDWOOD/BEECHWOOD LAMINATED VENEER LUMBER WOOD-WOOD
 $\alpha_1 = 45^\circ, \alpha_2 = 45^\circ$ - ASSY PLUS VG

ASSY plus VG - Lap shear capacity $F_{v,Rk}$ and $F_{v,Rd}$ ($k_{mod} = 0,8$ and $\gamma_M = 1,3$) with required minimum screw length l_{min}

t_1	Ø 6mm		Ø 8mm		Ø 10mm		Ø 12mm	
	$F_{v,R}$ kN	l_{min} mm	$F_{v,R}$ kN	l_{min} mm	$F_{v,R}$ kN	l_{min} mm	$F_{v,R}$ kN	l_{min} mm
30	3,14	100	4,01	120				
	1,93	100	2,47	120				
40	4,19	120	5,35	120	6,07	120		
	2,58	120	3,29	120	3,74	120		
50	5,24	160	6,68	160	7,59	160		
	3,22	160	4,11	160	4,67	160		
60	6,29	180	8,02	180	9,11	180		
	3,87	180	4,93	180	5,61	180		
80	7,78	220	10,7	240	12,1	240	14,6	240
	5,16	240	6,58	240	7,48	240	8,97	240
100	7,78	260	13,4	300	15,2	300	18,2	300

$F_{v,R}$ kN	l_{min} mm
$F_{v,Rk}$	
$F_{v,Rd}$	

Selected: ASSY plus VG cylinder head 8x240 mm

$F_{v,Rd} = 6,58 \text{ kN}$ (NKL = 1, KLED = „mean“)

NOTE: These represent planning aids. The values are to be measured by authorized persons for a specific project.

USE OF HARDWOOD / BEECHWOOD LVL / WOOD-WOOD SHEAR CONNECTION

Friction between the wood components may be estimated if pressure on the wood components is not impeded. ($\mu = 0,25$)

Required number of screws per side lumber piece for $n_{ef} = n$:

$$\text{erf. } n = F_{Ed} / (2 \times (1 + \mu) \times F_{v,Rd}) = 640 / (2 \times 1,25 \times 6,58) = 38,9$$

Minimum spacing per ETA-11/0190 A.1.4.2:

$$a_1 \geq 5 \times d = 40 \text{ mm} \quad \text{selected } 70 \text{ mm}$$

$$a_2 \geq 2,5 \times d = 20 \text{ mm} \quad \text{selected } 28 \text{ mm}$$

$$a_1 \times a_2 \geq 25 \times d^2$$

$$a_{1,c} \geq 5 \times d = 40 \text{ mm}$$

$$a_{2,c} \geq 3 \times d = 24 \text{ mm} \quad \text{selected } 34 \text{ mm}$$

Maximum number of screws at a right angle to the direction of the grain:

$$n_{90} = 1 + (h - 2 \times a_{2,c} - 1,5 \times d) / a_2 = 1 + (360 - 2 \times 34 - 1,5 \times 8) / 28 = 11$$

Number of screws in the direction of the grain in a row:

$$\text{erf. } n_0 = \text{erf. } n / n_{90} = 38,9 / 11 = 3,54$$

$$n_0 = 4$$

$$n_{0,ef} = \max\{n_0^{0,9}; 0,9 \times n_0\} = \max\{4^{0,9}; 0,9 \times 4\} = 3,6$$

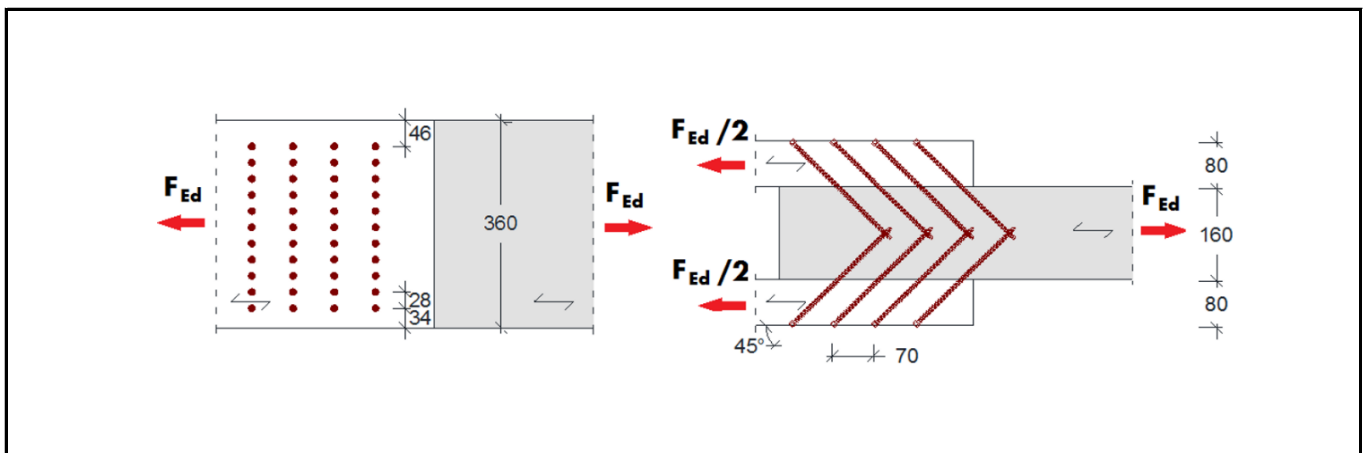

Verification of load capacity:

$$\frac{F_{v,Ed}}{n_{ef} \cdot F_{v,Rd}} = \frac{640}{2 \cdot 11 \cdot 3,6 \cdot 1,25 \cdot 6,58} = 0,98 \leq 1$$

Additional verification:

Shear capacity of the wood in the net cross section.

NOTE: These represent planning aids. The values are to be measured by authorized persons for a specific project.

USE FOR HARDWOOD/BEECHWOOD LAMINATED VENEER LUMBER/WOOD-WOOD

Sample calculation wood-wood; cross-cut wood connection

System: Post-bar connection
 Posts: $b/h = 160 \text{ mm} / 160 \text{ mm}$, hardwood, ($\rho_k = 680 \text{ kg/m}^3$)
 Bar: $b/h = 120 \text{ mm} / 240 \text{ mm}$, hardwood, ($\rho_k = 680 \text{ kg/m}^3$)
 Calculation base: Measurement: EC5 or DIN EN 1995-1-1:2010-12 and national German application document DIN 20000-6:2012-06; ETA 11/0190 ASSY wood screws.

Anchor force: $F_{Ed} = 20 \text{ kN}$ (NKL = 1, KLED = „mean“)

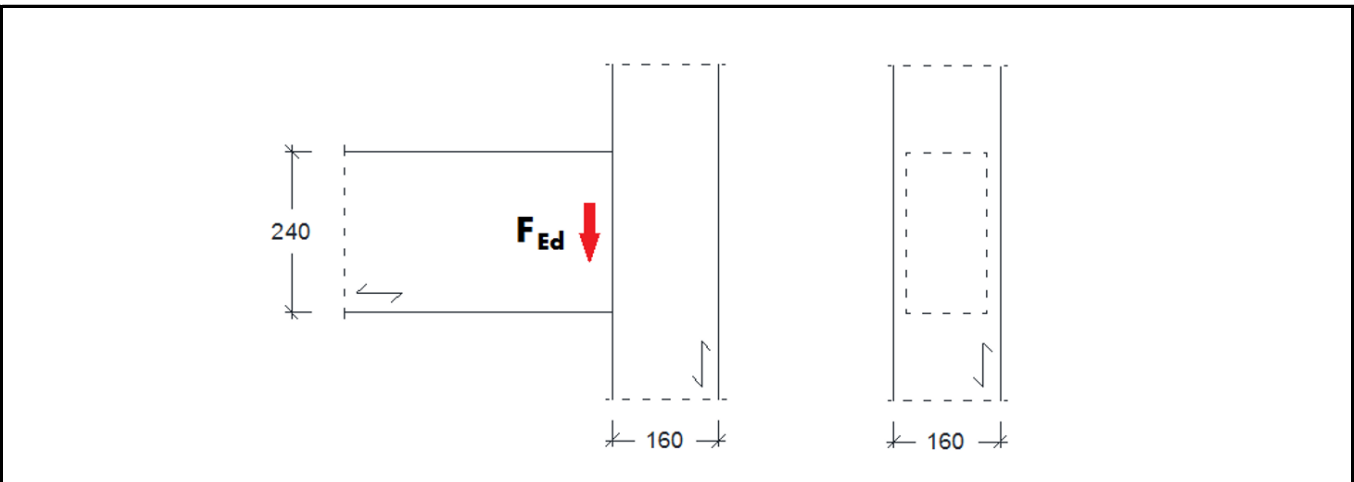

Alternative - ASSY 3.0 SK

Shear capacity hardwood/Beechwood laminated veneer lumber wood-wood $\alpha_1 = 90^\circ$, $\alpha_2 = 0^\circ$ - ASSY 3.0 SK

Screw head flush to the top of the post: $t_1 = 160 \text{ mm}$

SHEAR CAPACITY HARDWOOD/BEECHWOOD LAMINATED VENEER LUMBER WOOD-WOOD
 $\alpha_1 = 90^\circ$, $\alpha_2 = 0^\circ$ - ASSY 3.0 SK

SCHWERMET LAUBHOLZ/BAUHOLZ HOLZ-HOLZ $\alpha_1 = 90^\circ$, $\alpha_2 = 0^\circ$ - ASSY 3.0 SK

ASSY 3.0 SK - Schertragfähigkeit $F_{v,R}$ und $F_{v,Rd}$ ($k_{mod} = 0.8$) mit erforderlicher Mindestschraubentiefe t_{min}

t ₁ mm	Ø 5mm		Ø 6mm		Ø 8mm		Ø 10mm		Ø 12mm	
	F _{v,R} kN	t _{min} mm	F _{v,R} kN	t _{min} mm	F _{v,R} kN	t _{min} mm	F _{v,R} kN	t _{min} mm	F _{v,R} kN	t _{min} mm
24	1,96	120	2,68	110						
30	1,96	120	2,68	120	4,52	220				
140			2,68	240	4,52	260	6,59	320	9,17	380
160			2,68	260	4,52	280	6,59	320	9,17	380
180			2,68	280	4,52	300	6,59	320	9,17	380

ASSY 3.0 SK - Shear capacity $F_{v,Rk}$ and $F_{v,Rd}$ ($k_{mod} = 0.8$) with required minimum screw length

t ₁ mm	Ø 5mm		Ø 6mm		Ø 8mm		Ø 10mm		Ø 12mm	
	F _{v,Rk} kN	t _{min} mm	F _{v,Rk} kN	t _{min} mm	F _{v,Rk} kN	t _{min} mm	F _{v,Rk} kN	t _{min} mm	F _{v,Rk} kN	t _{min} mm
24	1,96	120	2,68	110						
30	1,96	120	2,68	120	4,52	220				
140			2,68	240	4,52	260	6,59	320	9,17	380
160			2,68	260	4,52	280	6,59	320	9,17	380
180			2,68	280	4,52	300	6,59	320	9,17	380

Selected: ASSY 3.0 SK 12x380 mm

$F_{v,Rd} = 5,64 \text{ kN}$ (NKL = 1, KLED = „mean“)

NOTE: These represent planning aids. The values are to be measured by authorized persons for a specific project.

USE FOR HARDWOOD/BEECHWOOD LAMINATED VENEER LUMBER/WOOD-WOOD

Minimum spacing

per DIN EN 1995-1-1:

Posts

$$a_1 \geq (4 + |\cos 0^\circ|) \times d = (4 + |\cos 0^\circ|) \times 12 = 40 \text{ mm}$$

$$a_2 \geq (3 + |\sin 0^\circ|) \times d = (3 + |\sin 0^\circ|) \times 12 = 36 \text{ mm}$$

$$a_{4,c} \geq 3 \times d = 3 \times 12 = 36 \text{ mm}$$

Support

$$a_2 \geq (3 + |\sin 90^\circ|) \times d = (3 + |\sin 90^\circ|) \times 12 = 48 \text{ mm}$$

$$a_{3,c} \geq 7 \times d = 7 \times 12 = 84 \text{ mm}$$

$$a_{4,i} \geq (3 + 4 \times \sin 90^\circ) \times d = (3 + 4 \times \sin 90^\circ) \times 12 = 84 \text{ mm}$$

$$a_{4,c} \geq 3 \times d = 3 \times 12 = 36 \text{ mm}$$

Effective number of screws:

$$a_1 = 10 \times d \rightarrow k_{ef} = 0,85$$

$$n_{0,ef} = n_0^{k_{ef}} = 2^{0,85} = 1,80$$

$$n_{ef} = n_{90} \times n_{0,ef} = 2 \times 1,80 = 3,60$$

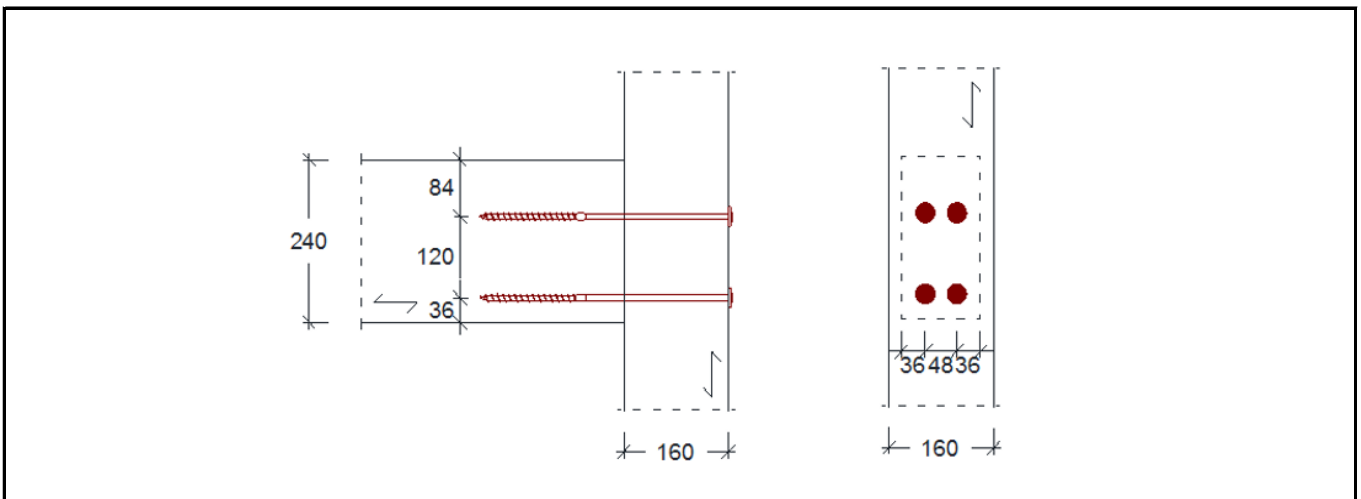

Verification of load capacity:

$$\frac{F_{Ed}}{n_{ef} \cdot F_{v,Rd}} = \frac{20}{3,60 \cdot 5,64} = 0,99 \leq 1$$

Verification of the transverse connection is satisfied whilst $h_1 / h > 0,7$.

NOTE: These represent planning aids. The values are to be measured by authorized persons for a specific project.

KEY TABLES BEECHWOOD LAMINATED VENEER LUMBER/WOOD-WOOD CONNECTIONS

Key

$F_{ax,Rk}$ Characteristic load capacity in [kN] for a screw when being withdrawn at an angle between the veneer layers and screw axis of 0° or 90° .

$F_{ax,Rd}$ Pull: Rated value for load capacity in [kN] for a screw when being withdrawn for an angle between the veneer layers and screw axis of 0° or 90° with $k_{mod} = 0,8$ and $\gamma_M = 1,3$ dependent upon the thread reach.

Press: $\min \{k_{mod} / \gamma_M \times F_{ax,Rk}; k_c \times N_{pl,d}\}$

$k_c \times N_{pl,d}$ Rated value per the max. load capacity of a screw under pressure

$F_{v,Rk}$ Characteristic load capacity in [kN] for a screw for shearing at an angle between the veneer layers and screw axis of 0° or 90° . In the case of tensile shear strength, the angle between the screw axis and the shear force is 45° .

$F_{v,Rd}$ Rated value for load capacity in [kN] for a screw for shearing at an angle between the veneer layers and screw axis of 0° or 90° with $k_{mod} = 0,8$ and $\gamma_M = 1,3$. In the case of tensile shear strength, the angle between the screw axis and the shear force is 45° .

F_{tens} Load capacity for tearing out

α_i Angle between screw axis and grain / ply direction of the component's veneers

l Screw length in [mm]

l_{min} Minimum screw length with which the indicated load capacity is achieved in [mm]

l_{ef} Effective anchorage length of the threads in cm; withdrawal capacity ASSY plus VG

d Nominal diameter/Thread outer diameter for screws in [mm]

t_1 Side lumber thickness on the screw head side in [mm]; the minimum component thickness is at least 24 mm (see A1.4 ETA 11/0190)

t_2 Side lumber thickness on the screw tip side component 2 at $\alpha = 0^\circ$ or 90° in [mm]: $t_2 \geq l_{min} - t_1$

Side lumber thickness on the screw tip side component 2 (shear application) $\alpha = 45^\circ$ in [mm]; component 2: $t_2 \geq l_{min} / 1,414 - t_1$

m Installation dimensions

b_{NT} Minimum width of the side bar

h_{NT} Minimum height of the side bar

b_{HT} Minimum width of the main bar

h_{HT} Minimum height of the main bar

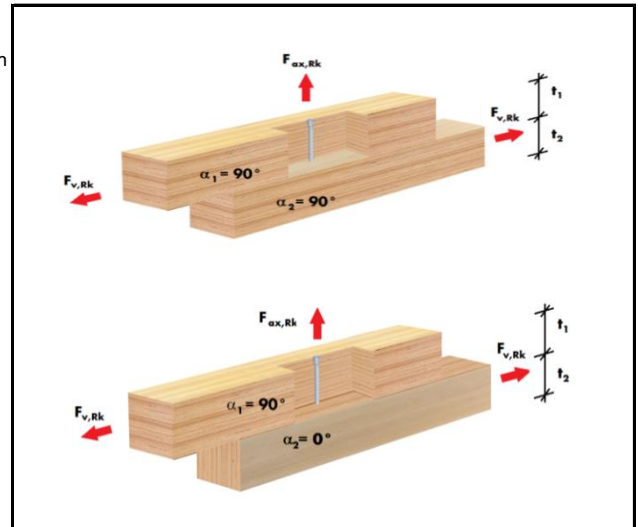

Explanatory notes to the tables

	$F_{v,R} / F_{ax,R}$	l_{min}	
	kN	mm	
Characteristic value $F_{v,Rk}$ and/or $F_{ax,Rk}$	10,3	380	l_{min} for $F_{v,Rk}$ and/or $F_{ax,Rk}$
Rated value ($k_{mod} = 0,8$) $F_{v,Rd}$ and/or $F_{ax,Rd}$	17,7	380	l_{min} for $F_{v,Rd}$ and/or $F_{ax,Rd}$

NOTE: These represent planning aids. The values are to be measured by authorized persons for a specific project.

KEY TABLES BEECHWOOD LAMINATED VENEER LUMBER/WOOD-WOOD CONNECTIONS

General information

- Single shear wood-wood connection with screws in pre-drilled holes. Calculated values apply to Beechwood laminated veneer lumber that conforms to product-specific AbZ Z-9.1-837. All screws must be installed flush.
- Pre-drilled hole diameter per ETA-11/0190

Thread outer diameter in mm	5	6	7	8	10	12	14
Pre-drill diameter in mm	3,5	4	5	6	7	8	9

- Screws made of carbon steel may only be used in use categories 1 and 2. (exception: hot-dip galvanized ASSY plus VG Ø14)
- Individual load capacity for a screw with a characteristic density of $\rho_k \geq 680 \text{ kg/m}^3$. The characteristic density was limited to $\rho_k \geq 590 \text{ kg/m}^3$ for axial loads. In the case of connections using multiple screws, the effective number of screws n_{ef} per DIN EN 1995-1-1 (8.17) and/or ETA-11/0190 A.1.3.1 must be adhered to.
- Load-bearing connections must comprise at least two screws. Deviations from this are possible per DIN EN 1995-1-1/NA:2010-12, NCI to 8.3.1.2 (NA.10) and ETA-11/0190, 4.2.
- ASSY 3.0 Combi with U-washer per EN ISO 7094 or DIN 1052: Characteristic transverse compressive capacity of the wood at least $8,5 \text{ N/mm}^2$
- Shear application: The value for shear capacity F_v can be multiplied by 1.25 if friction between the two components is taken into account.
- Main / side bar connection: Main bar and side bar top edge must be positioned flush. The main bar must be torsion-resistant. Additional moments based on eccentricity of the connection as well as cross-section weaknesses resulting from connectors must be taken into consideration in the verification of the components. The minimum spacing for the screws per ETA-11/0190 must be complied with. $a_{2,c} = 3 \times d$; $s = 1,5 \times d$

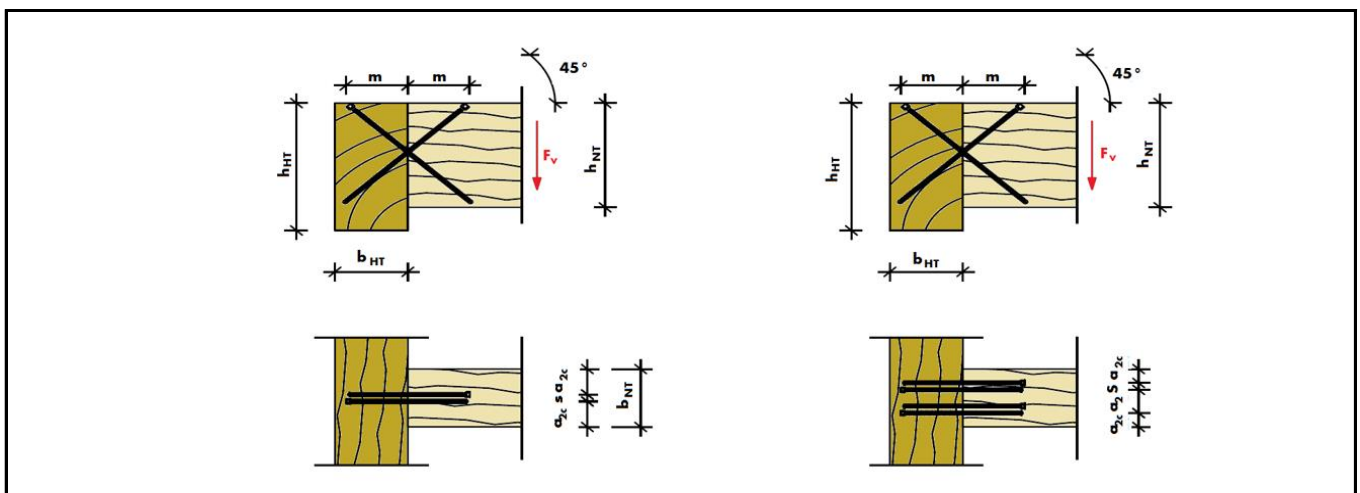

Calculation bases

DIN EN 1995-1-1:2010-12	Measurement and design of wooden structures - General rules and rules for wooden construction
DIN EN 1995-1-1/NA:2013-08	National application - Nationally-defined parameters
DIN 20000-6	Use of construction products in structures Part 6: Dowel type and non-dowel type fasteners
ETA-11/0190	Würth self-tapping screws for use in timber constructions
AbZ Z-9.1-837	Laminated timber from beechwood - veneer laminates

NOTE: These represent planning aids. The values are to be measured by authorized persons for a specific project.

SHEAR CAPACITY HARDWOOD/BEECHWOOD LAMINATED VENEER LUMBER/WOOD-WOOD

$\alpha_1 = 90^\circ, \alpha_2 = 90^\circ$ - ASSY 3.0 - ASSY 3.0 ZINI

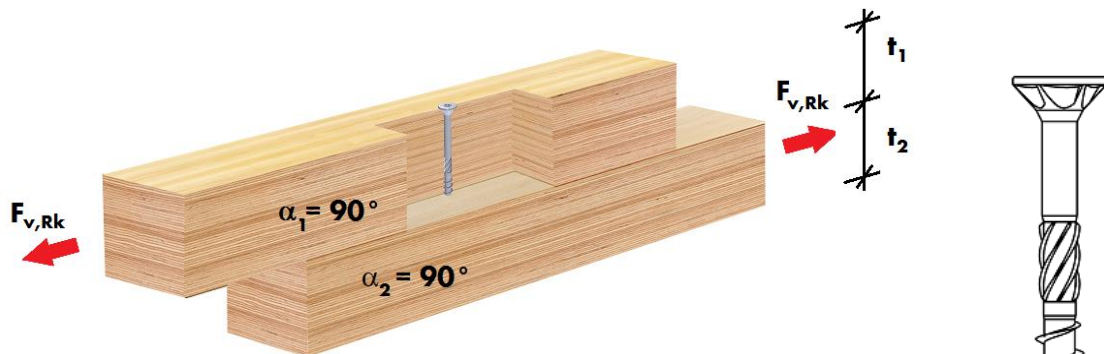

ASSY 3.0 - Shear capacity $F_{v,Rk}$ and $F_{v,Rd}$ ($k_{mod} = 0,8$) with required minimum screw length l_{min}

t_1 mm	Ø 5mm		Ø 6mm		Ø 7mm		Ø 8mm		Ø 10mm	
	$F_{v,R}$ kN	l_{min} mm	$F_{v,R}$ kN	l_{min} mm	$F_{v,R}$ kN	l_{min} mm	$F_{v,R}$ kN	l_{min} mm	$F_{v,R}$ kN	l_{min} mm
24	2,48	45	3,52	60	4,58	80				
	1,53	45	2,17	60	2,82	80				
30	2,48	50	3,52	60	4,61	80	5,75	80		
	1,53	50	2,17	60	2,84	80	3,54	80		
40	2,48	60	3,52	70	4,61	80	5,75	80	8,55	100
	1,53	60	2,17	70	2,84	80	3,54	80	5,26	100
50	2,49	70	3,52	80	4,61	90	5,75	100	8,55	100
	1,53	70	2,17	80	2,84	90	3,54	100	5,26	100
60	2,49	80	3,52	90	4,61	100	5,75	100	8,55	120
	1,53	80	2,17	90	2,84	100	3,54	100	5,26	120
80	2,53	110	3,60	110	4,61	120	6,00	120	8,55	140
	1,56	110	2,21	110	2,84	120	3,69	120	5,26	140
100	2,49	120	3,60	130	4,61	140	6,00	140	8,55	160
	1,53	120	2,21	130	2,84	140	3,69	140	5,26	160
120			3,60	150	4,89	160	6,00	160	8,55	180
			2,21	150	3,01	160	3,69	160	5,26	180
140			3,60	180	4,89	180	6,00	180	8,55	200
			2,21	180	3,01	180	3,69	180	5,26	200
160			3,60	200	4,89	200	6,00	200	8,55	220
			2,21	200	3,01	200	3,69	200	5,26	220
180			3,60	220	4,89	220	6,00	220	8,55	240
			2,21	220	3,01	220	3,69	220	5,26	240
200			3,60	240	4,89	240	6,00	240	8,55	260
			2,21	240	3,01	240	3,69	240	5,26	260
220			3,60	260	4,89	260	6,00	260	8,55	280
			2,21	260	3,01	260	3,69	260	5,26	280
240			3,60	280	4,89	280	6,00	280	8,55	300
			2,21	280	3,01	280	3,69	280	5,26	300
260			3,60	300	4,89	300	6,00	300	9,19	320
			2,21	300	3,01	300	3,69	300	5,66	320
280							6,00	320	9,19	340
							3,69	320	5,66	340
300							6,00	340	9,19	360
							3,69	340	5,66	360
320							6,00	360	9,19	380
							3,69	360	5,66	380

$F_{v,R}$ kN	l_{min} mm
	$F_{v,Rk}$
	$F_{v,Rd}$

General information

ASSY screws are to be pre-drilled for hardwood or Beechwood laminated veneer lumber per ETA-11/0190 Table 1.

Ø	Pre-drilling Ø
5 mm	3.5 mm
6 mm	4 mm
7 mm	5 mm
8 mm	6 mm
10 mm	7 mm
12 mm	8 mm
14 mm	9 mm

Calculation base

- ETA-11/0190
- EN 1995-1-1:2010-12

The exceptions listed in key chapter must be taken into consideration.

NOTE: These represent planning aids. The values are to be measured by authorized persons for a specific project.

SHEAR CAPACITY HARDWOOD/BEECHWOOD LAMINATED VENEER LUMBER/WOOD-WOOD

$\alpha_1 = 90^\circ, \alpha_2 = 90^\circ$ ASSY 3.0 SK

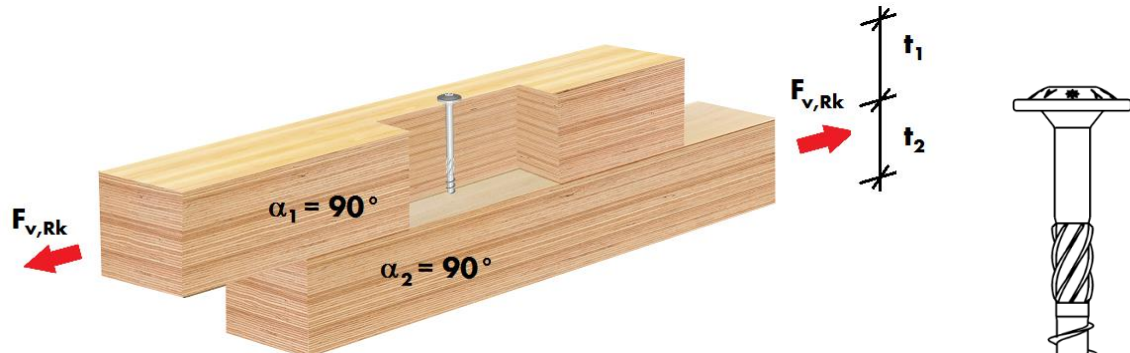

ASSY 3.0 SK - Shear capacity $F_{v,Rk}$ and $F_{v,Rd}$ ($k_{mod} = 0,8$) with required minimum screw length l_{min}

t_1 mm	Ø 5mm		Ø 6mm		Ø 8mm		Ø 10mm		Ø 12mm	
	$F_{v,R}$ kN	l_{min} mm	$F_{v,R}$ kN	l_{min} mm	$F_{v,R}$ kN	l_{min} mm	$F_{v,R}$ kN	l_{min} mm	$F_{v,R}$ kN	l_{min} mm
24	2,74	60	3,78	70						
	1,69	60	2,33	70						
30	2,74	70	3,78	70	6,50	100				
	1,69	70	2,33	70	4,00	100				
40	2,74	80	3,78	80	6,50	100	9,29	120		
	1,69	80	2,33	80	4,00	100	5,71	120		
50	2,49	70	3,78	90	6,50	120	9,29	120		
	1,53	70	2,33	90	4,00	120	5,71	120		
60	2,49	80	3,78	100	6,50	120	9,29	140		
	1,53	80	2,33	100	4,00	120	5,71	140		
80	2,74	120	3,78	120	6,50	140	8,43	120	12,7	200
	1,69	120	2,33	120	4,00	140	5,19	120	7,81	200
100	2,49	120	3,78	140	6,50	160	9,19	160	12,7	200
	1,53	120	2,33	140	4,00	160	5,66	160	7,81	200
120			3,78	160	6,50	180	9,19	180	12,7	200
			2,33	160	4,00	180	5,66	180	7,81	200
140			3,78	180	6,50	200	9,19	200	12,7	220
			2,33	180	4,00	200	5,66	200	7,81	220
160			3,78	200	6,50	220	9,19	220	12,2	220
			2,33	200	4,00	220	5,66	220	7,53	220
180			3,78	220	6,50	240	9,19	240	12,2	240
			2,33	220	4,00	240	5,66	240	7,53	240
200			3,78	240	6,50	260	9,19	260	12,2	260
			2,33	240	4,00	260	5,66	260	7,53	260
220			3,78	260	6,50	280	9,19	280	12,2	280
			2,33	260	4,00	280	5,66	280	7,53	280
240			3,78	280	6,50	300	9,29	320	12,2	300
			2,33	280	4,00	300	5,71	320	7,53	300
260			3,78	300	6,50	320	9,29	340	12,2	320
			2,33	300	4,00	320	5,71	340	7,53	320
280					6,50	340	9,29	360	12,2	340
					4,00	340	5,71	360	7,53	340
300					6,50	360	9,29	380	12,7	380
					4,00	360	5,71	380	7,81	380
320					6,50	380	9,29	400	12,7	400
					4,00	380	5,71	400	7,81	400

$F_{v,R}$ kN	l_{min} mm
	$F_{v,Rk}$
	$F_{v,Rd}$

General information

ASSY screws are to be pre-drilled for hardwood or Beechwood laminated veneer lumber per ETA-11/0190 Table 1.

Ø	Pre-drilling Ø
5 mm	3.5 mm
6 mm	4 mm
7 mm	5 mm
8 mm	6 mm
10 mm	7 mm
12 mm	8 mm
14 mm	9 mm

Calculation base

- ETA-11/0190
- EN 1995-1-1:2010-12

The exceptions listed in key chapter must be taken into consideration.

NOTE: These represent planning aids. The values are to be measured by authorized persons for a specific project.

SHEAR CAPACITY HARDWOOD/BEECHWOOD LAMINATED VENEER LUMBER/WOOD-WOOD

$\alpha_1 = 90^\circ, \alpha_2 = 90^\circ$ ASSY 3.0 COMBI

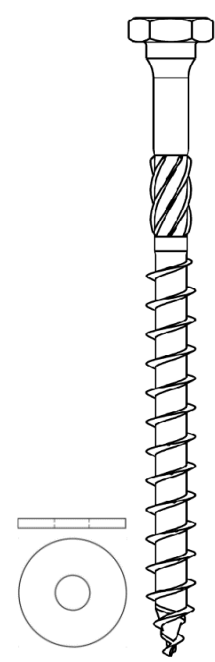
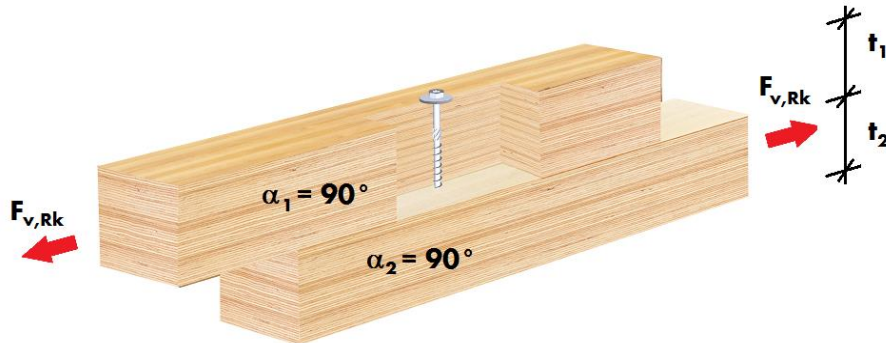

ASSY 3.0 Combi with U-washer - Shear capacity $F_{v,Rk}$ and $F_{v,Rd}$ ($k_{mod} = 0,8$) with required minimum screw length l_{min}

t_1 mm	$\varnothing 8/d2 28mm$		$\varnothing 10/d2 34mm$		$\varnothing 12/d2 34mm$	
	$F_{v,R}$ kN	l_{min} mm	$F_{v,R}$ kN	l_{min} mm	$F_{v,R}$ kN	l_{min} mm
40	7,33	140	10,7	160		
	4,51	140	6,59	160		
60	8,00	220	10,7	180		
	4,92	220	6,59	180		
80	8,00	220	10,7	200	15,0	220
	4,92	220	6,59	200	9,21	220
100	8,00	220	10,7	220	15,0	240
	4,92	220	6,59	220	9,21	240
120	8,00	240	10,7	240	15,0	260
	4,92	240	6,59	240	9,21	260
140	8,00	260	10,7	260	15,0	280
	4,92	260	6,59	260	9,21	280
160	8,00	280	11,5	320	15,0	300
	4,92	280	7,06	320	9,21	300
180	8,00	300	11,5	320	15,0	320
	4,92	300	7,06	320	9,21	320
200	7,90	300	11,5	340	15,0	340
	4,86	300	7,06	340	9,21	340
220	7,23	300	11,5	360	16,1	380
	4,45	300	7,06	360	9,91	380
240	6,56	300	11,5	380	16,1	400
	4,04	300	7,06	380	9,91	400
260	5,90	300	11,5	400	15,7	400
	3,63	300	7,06	400	9,66	400
280			11,4	400	16,1	440
			6,99	400	9,91	440
300			10,6	400	15,7	440
			6,52	400	9,66	440
320			9,84	400	16,1	480
			6,05	400	9,91	480
340			9,08	400	15,7	480
			5,59	400	9,66	480
360					14,8	480
					9,10	480
380					13,9	480
					8,54	480

DIN EN ISO 7094

$F_{v,R}$ kN	l_{min} mm
	$F_{v,Rk}$
	$F_{v,Rd}$

General information

ASSY screws are to be pre-drilled for hardwood or Beechwood laminated veneer lumber per ETA-11/0190 Table 1.

\varnothing	Pre-drilling \varnothing
5 mm	3.5 mm
6 mm	4 mm
7 mm	5 mm
8 mm	6 mm
10 mm	7 mm
12 mm	8 mm

Calculation base

- ETA-11/0190
- EN 1995-1-1:2010-12

Penetration resistance corresponding to the bolts per N1995-1-1:2010-12. The exceptions listed in key chapter must be taken into consideration.

NOTE: These represent planning aids. The values are to be measured by authorized persons for a specific project.

SHEAR CAPACITY HARDWOOD/BEECHWOOD LAMINATED VENEER LUMBER/WOOD-WOOD

$\alpha_1 = 90^\circ, \alpha_2 = 90^\circ$ ASSY PLUS VG

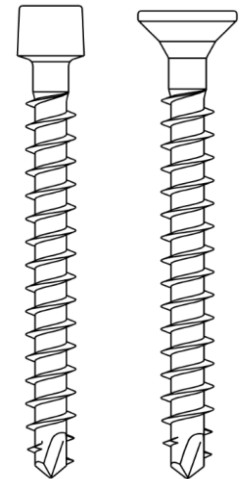
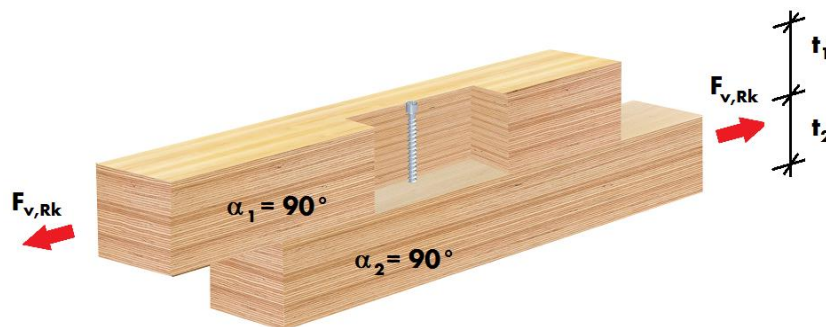

ASSY plus VG - Shear capacity $F_{v,Rk}$ and $F_{v,Rd}$ ($k_{mod} = 0,8$) with required minimum screw length l_{min}

t_1 mm	Ø 6mm		Ø 8mm		Ø 10mm		Ø 12mm	
	$F_{v,R}$ kN	l_{min} mm	$F_{v,R}$ kN	l_{min} mm	$F_{v,R}$ kN	l_{min} mm	$F_{v,R}$ kN	l_{min} mm
30	3,60	80	4,66	120				
	2,21	80	2,87	120				
40	3,86	80	6,00	120	8,43	120		
	2,37	80	3,69	120	5,19	120		
50	4,12	100	6,33	120	8,81	120		
	2,54	100	3,90	120	5,42	120		
60	4,38	120	6,66	120	9,19	120		
	2,70	120	4,10	120	5,66	120		
80	4,91	160	7,33	160	9,95	160	13,1	160
	3,02	160	4,51	160	6,12	160	8,09	160
100	5,43	200	8,00	200	10,7	200	14,1	200
	3,34	200	4,92	200	6,59	200	8,65	200
120	5,56	240	8,67	240	11,5	240	15,0	240
	3,42	240	5,33	240	7,06	240	9,21	240
140	5,56	260	9,32	280	12,2	280	15,9	280
	3,42	260	5,73	280	7,52	280	9,77	280
160	5,43	260	9,32	300	13,0	320	16,8	380
	3,34	260	5,73	300	7,99	320	10,3	380
180	4,91	260	9,32	330	13,7	360	17,7	380
	3,02	260	5,73	330	8,46	360	10,9	380
200	4,38	260	9,32	380	13,8	400	18,6	480
	2,70	260	5,73	380	8,51	400	11,5	480
220	3,86	260	9,32	380	13,8	430	19,0	480
	2,37	260	5,73	380	8,51	430	11,7	480
240			9,32	380	13,8	430	19,0	480
			5,73	380	8,51	430	11,7	480
260			9,32	430	13,8	480	19,0	480
			5,73	430	8,51	480	11,7	480
280			9,32	430	13,8	480	19,0	600
			5,73	430	8,51	480	11,7	600
300			9,32	480	13,8	530	19,0	600
			5,73	480	8,51	530	11,7	600

$F_{v,R}$ kN	l_{min} mm
	$F_{v,Rk}$
	$F_{v,Rd}$

General information

ASSY screws are to be pre-drilled for hardwood or Beechwood laminated veneer lumber per ETA-11/0190 Table 1.

Ø	Pre-drilling Ø
5 mm	3.5 mm
6 mm	4 mm
7 mm	5 mm
8 mm	6 mm
10 mm	7 mm
12 mm	8 mm
14 mm	9 mm

Calculation base

- ETA-11/0190
- EN 1995-1-1:2010-12

The exceptions listed in key chapter must be taken into consideration.

NOTE: These represent planning aids. The values are to be measured by authorized persons for a specific project.

SHEAR CAPACITY HARDWOOD/BEECHWOOD LAMINATED VENEER LUMBER/WOOD-WOOD

$\alpha_1 = 90^\circ, \alpha_2 = 90^\circ$ ASSY PLUS VG $\varnothing 14$ MM

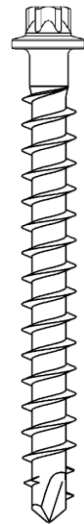
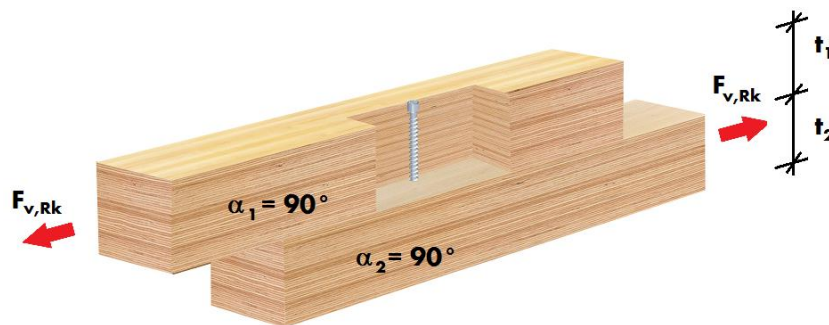

ASSY plus VG $\varnothing 14$ mm - Shear capacity $F_{v,Rk}$ and $F_{v,Rd}$ ($k_{mod} = 0,8$) with required minimum screw length l_{min}

t_1 mm	$\varnothing 14$ mm	
	$F_{v,R}$ kN	l_{min} mm
200	22,1	400
	13,6	400
240	23,0	800
	14,2	800
280	23,0	800
	14,2	800
320	23,0	800
	14,2	800
360	23,0	800
	14,2	800
400	23,0	800
	14,2	800
440	23,0	800
	14,2	800
480	23,0	800
	14,2	800
520	23,0	800
	14,2	800
560	23,0	800
	14,2	800
600	23,0	850
	14,2	850
640	23,0	900
	14,2	900
680	23,0	900
	14,2	900
720	23,0	950
	14,2	950
760	23,0	1000
	14,2	1000
800	23,0	1050
	14,2	1050

$F_{v,R}$ kN	l_{min} mm
	$F_{v,Rk}$
	$F_{v,Rd}$

General information

ASSY screws are to be pre-drilled for hardwood or Beechwood laminated veneer lumber per ETA-11/0190 Table 1.

\varnothing	Pre-drilling \varnothing
5 mm	3.5 mm
6 mm	4 mm
7 mm	5 mm
8 mm	6 mm
10 mm	7 mm
12 mm	8 mm
14 mm	9 mm

Calculation base

- ETA-11/0190
- EN 1995-1-1:2010-12

The exceptions listed in key chapter must be taken into consideration.

NOTE: These represent planning aids. The values are to be measured by authorized persons for a specific project.

SHEAR CAPACITY HARDWOOD/BEECHWOOD LAMINATED VENEER LUMBER/WOOD-WOOD

$\alpha_1 = 90^\circ, \alpha_2 = 0^\circ$ ASSY 3.0 - ASSY 3.0 ZINI

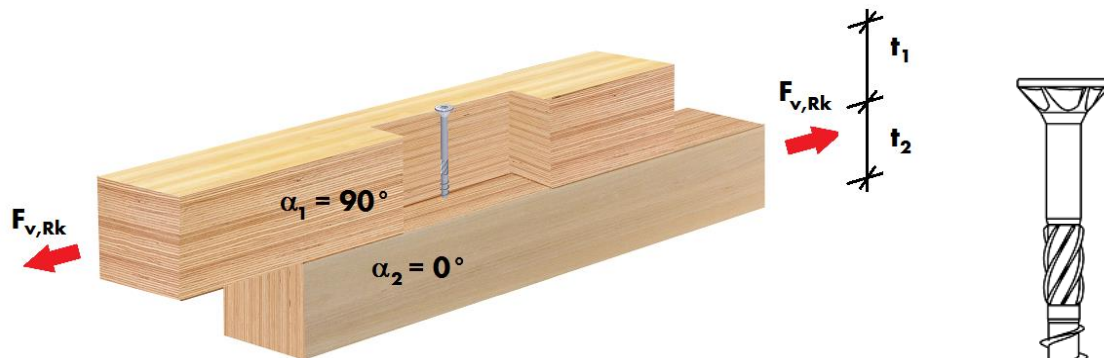

ASSY 3.0 - Shear capacity $F_{v,Rk}$ and $F_{v,Rd}$ ($k_{mod} = 0,8$) with required minimum screw length l_{min}

t_1 mm	Ø 5mm		Ø 6mm		Ø 7mm		Ø 8mm		Ø 10mm	
	$F_{v,R}$ kN	l_{min} mm	$F_{v,R}$ kN	l_{min} mm	$F_{v,R}$ kN	l_{min} mm	$F_{v,R}$ kN	l_{min} mm	$F_{v,R}$ kN	l_{min} mm
24	1,96	120	2,68	110	3,55	160				
	1,21	120	1,65	110	2,19	160				
30	1,96	120	2,68	120	3,55	160	4,52	220		
	1,21	120	1,65	120	2,19	160	2,78	220		
40	1,96	120	2,68	130	3,55	160	4,52	220	6,59	320
	1,21	120	1,65	130	2,19	160	2,78	220	4,06	320
50	1,96	120	2,68	140	3,55	160	4,52	220	6,59	320
	1,21	120	1,65	140	2,19	160	2,78	220	4,06	320
60			2,68	150	3,55	160	4,52	220	6,59	320
			1,65	150	2,19	160	2,78	220	4,06	320
80			2,68	180	3,55	180	4,52	220	6,59	320
			1,65	180	2,19	180	2,78	220	4,06	320
100			2,68	200	3,55	200	4,52	220	6,59	320
			1,65	200	2,19	200	2,78	220	4,06	320
120			2,68	220	3,55	220	4,52	240	6,59	320
			1,65	220	2,19	220	2,78	240	4,06	320
140			2,68	240	3,55	240	4,52	260	6,59	320
			1,65	240	2,19	240	2,78	260	4,06	320
160			2,68	260	3,55	260	4,52	280	6,59	320
			1,65	260	2,19	260	2,78	280	4,06	320
180			2,68	280	3,55	280	4,52	300	6,59	320
			1,65	280	2,19	280	2,78	300	4,06	320
200			2,68	300	3,55	300	4,52	320	6,59	340
			1,65	300	2,19	300	2,78	320	4,06	340
220							4,52	340	6,59	360
							2,78	340	4,06	360
240							4,52	360	6,59	380
							2,78	360	4,06	380
260							4,52	380	6,59	400
							2,78	380	4,06	400
280							4,52	400		
							2,78	400		
300										
320										

$F_{v,R}$ kN	l_{min} mm
	$F_{v,Rk}$
	$F_{v,Rd}$

General information

ASSY screws are to be pre-drilled for hardwood or Beechwood laminated veneer lumber per ETA-11/0190 Table 1.

Ø	Pre-drilling Ø
5 mm	3.5 mm
6 mm	4 mm
7 mm	5 mm
8 mm	6 mm
10 mm	7 mm
12 mm	8 mm
14 mm	9 mm

Calculation base

- ETA-11/0190
- EN 1995-1-1:2010-12

The exceptions listed in key chapter must be taken into consideration.

NOTE: These represent planning aids. The values are to be measured by authorized persons for a specific project.

SHEAR CAPACITY HARDWOOD/BEECHWOOD LAMINATED VENEER LUMBER/WOOD-WOOD

$\alpha_1 = 90^\circ, \alpha_2 = 0^\circ$ ASSY 3.0 SK

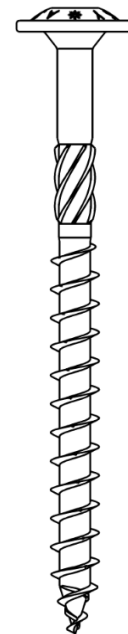
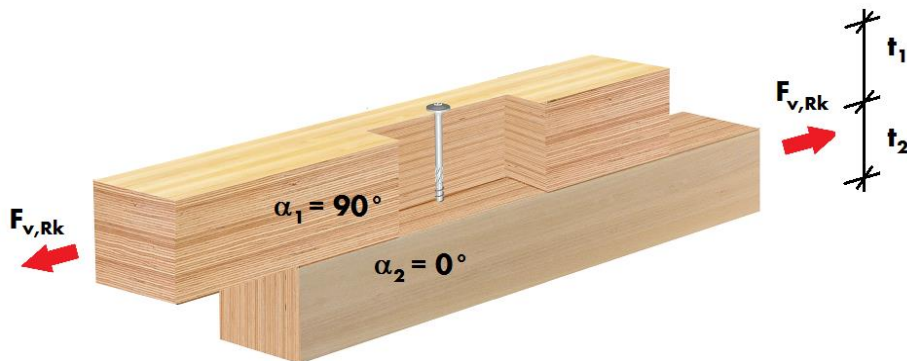

ASSY 3.0 SK - Shear capacity $F_{v,Rk}$ and $F_{v,Rd}$ ($k_{mod} = 0,8$) with required minimum screw length l_{min}

t_1 mm	Ø 5mm		Ø 6mm		Ø 8mm		Ø 10mm		Ø 12mm	
	$F_{v,R}$ kN	l_{min} mm	$F_{v,R}$ kN	l_{min} mm	$F_{v,R}$ kN	l_{min} mm	$F_{v,R}$ kN	l_{min} mm	$F_{v,R}$ kN	l_{min} mm
24	1,96	120	2,68	110						
	1,21	120	1,65	110						
30	1,96	120	2,68	120	4,52	220				
	1,21	120	1,65	120	2,78	220				
40	1,96	120	2,68	140	4,52	220	6,59	320		
	1,21	120	1,65	140	2,78	220	4,06	320		
50	1,96	120	2,68	140	4,52	220	6,59	320		
	1,21	120	1,65	140	2,78	220	4,06	320		
60			2,68	160	4,52	220	6,59	320		
			1,65	160	2,78	220	4,06	320		
80			2,68	180	4,52	220	6,59	320	9,17	380
			1,65	180	2,78	220	4,06	320	5,64	380
100			2,68	200	4,52	220	6,59	320	9,17	380
			1,65	200	2,78	220	4,06	320	5,64	380
120			2,68	220	4,52	240	6,59	320	9,17	380
			1,65	220	2,78	240	4,06	320	5,64	380
140			2,68	240	4,52	260	6,59	320	9,17	380
			1,65	240	2,78	260	4,06	320	5,64	380
160			2,68	260	4,52	280	6,59	320	9,17	380
			1,65	260	2,78	280	4,06	320	5,64	380
180			2,68	280	4,52	300	6,59	320	9,17	380
			1,65	280	2,78	300	4,06	320	5,64	380
200			2,68	300	4,52	320	6,59	340	9,17	380
			1,65	300	2,78	320	4,06	340	5,64	380
220					4,52	340	6,59	360	9,17	400
					2,78	340	4,06	360	5,64	400
240					4,52	360	6,59	380	9,17	440
					2,78	360	4,06	380	5,64	440
260					4,52	380	6,59	400	9,17	440
					2,78	380	4,06	400	5,64	440
280					4,52	400	6,59	420	9,17	480
					2,78	400	4,06	420	5,64	480
300					4,52	420	6,59	440	9,17	480
					2,78	420	4,06	440	5,64	480
320					4,52	440	6,59	460	9,17	520
					2,78	440	4,06	460	5,64	520

$F_{v,R}$ kN	l_{min} mm
	$F_{v,Rk}$
	$F_{v,Rd}$

General information

ASSY screws are to be pre-drilled for hardwood or Beechwood laminated veneer lumber per ETA-11/0190 Table 1.

Ø	Pre-drilling Ø
5 mm	3.5 mm
6 mm	4 mm
7 mm	5 mm
8 mm	6 mm
10 mm	7 mm
12 mm	8 mm
14 mm	9 mm

Calculation base

- ETA-11/0190
- EN 1995-1-1:2010-12

The exceptions listed in key chapter must be taken into consideration.

NOTE: These represent planning aids. The values are to be measured by authorized persons for a specific project.

SHEAR CAPACITY HARDWOOD/BEECHWOOD LAMINATED VENEER LUMBER/WOOD-WOOD

$\alpha_1 = 90^\circ, \alpha_2 = 0^\circ$ ASSY 3.0 COMBI

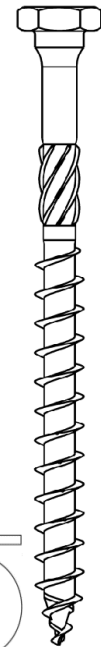
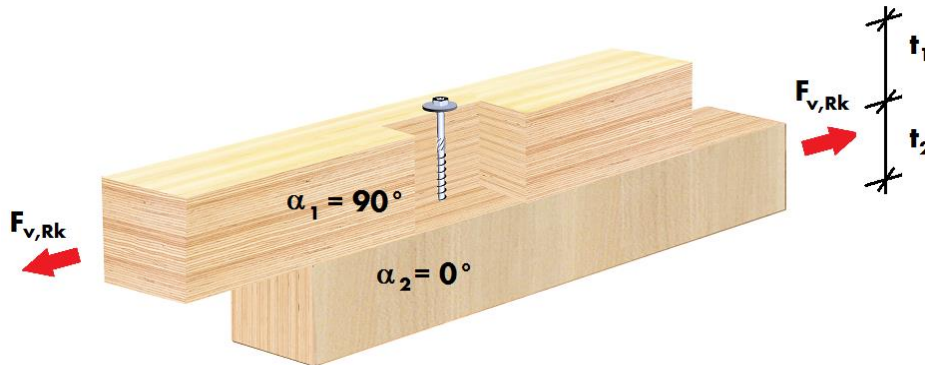

DIN EN ISO 7094

$F_{v,R}$ kN	l_{min} mm
	$F_{v,Rk}$
	$F_{v,Rd}$

ASSY 3.0 Combi with U-washer - Shear capacity $F_{v,Rk}$ and $F_{v,Rd}$ ($k_{mod} = 0,8$) with required minimum screw length l_{min}

t_1 mm	Ø 8/d2 28mm		Ø 10/d2 34mm		Ø 12/d2 34mm	
	$F_{v,R}$ kN	l_{min} mm	$F_{v,R}$ kN	l_{min} mm	$F_{v,R}$ kN	l_{min} mm
40	4,52	220	6,59	320		
	2,78	220	4,06	320		
60	4,52	220	6,59	320		
	2,78	220	4,06	320		
80	4,52	220	6,59	320	9,17	380
	2,78	220	4,06	320	5,64	380
100	4,52	220	6,59	320	9,17	380
	2,78	220	4,06	320	5,64	380
120	4,52	240	6,59	320	9,17	380
	2,78	240	4,06	320	5,64	380
140	4,52	260	6,59	320	9,17	380
	2,78	260	4,06	320	5,64	380
160	4,52	280	6,59	320	9,17	380
	2,78	280	4,06	320	5,64	380
180	4,52	300	6,59	340	9,17	380
	2,78	300	4,06	340	5,64	380
200			6,59	360	9,17	380
			4,06	360	5,64	380
220			6,59	380	9,17	400
			4,06	380	5,64	400
240			6,59	400	9,17	440
			4,06	400	5,64	440
260					9,17	440
					5,64	440
280					9,17	480
					5,64	480
300					9,17	480
					5,64	480
320						
340						
360						
380						

General information

ASSY screws are to be pre-drilled for hardwood or Beechwood laminated veneer lumber per ETA-11/0190 Table 1.

Ø	Pre-drilling Ø
5 mm	3,5 mm
6 mm	4 mm
7 mm	5 mm
8 mm	6 mm
10 mm	7 mm
12 mm	8 mm
14 mm	9 mm

Calculation base

- ETA-11/0190
 - EN 1995-1-1:2010-12
- Penetration resistance corresponding to the bolts per N1995-1-1:2010-12. The exceptions listed in key chapter must be taken into consideration.

NOTE: These represent planning aids. The values are to be measured by authorized persons for a specific project.

SHEAR CAPACITY HARDWOOD/BEECHWOOD LAMINATED VENEER LUMBER/WOOD-WOOD

$\alpha_1 = 90^\circ, \alpha_2 = 0^\circ$ ASSY PLUS VG

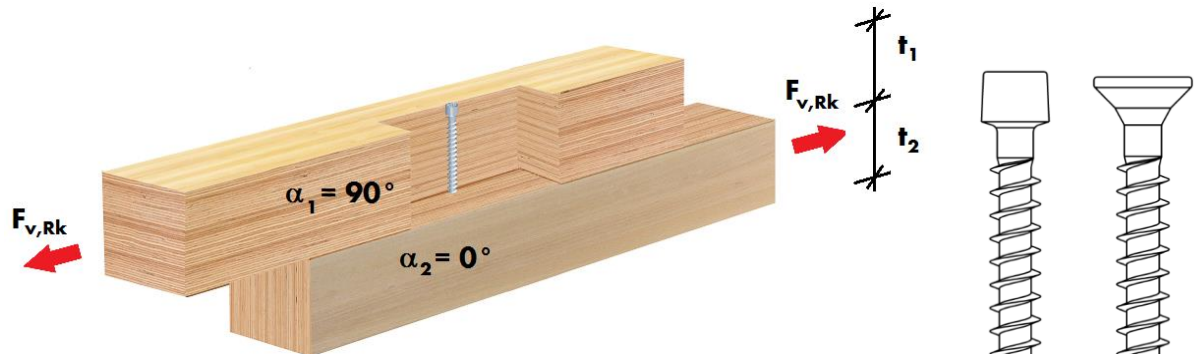

ASSY plus VG - Shear capacity $F_{v,Rk}$ and $F_{v,Rd}$ ($k_{mod} = 0,8$) with required minimum screw length l_{min}

t_1 mm	Ø 6mm		Ø 8mm		Ø 10mm		Ø 12mm	
	$F_{v,R}$ kN	l_{min} mm	$F_{v,R}$ kN	l_{min} mm	$F_{v,R}$ kN	l_{min} mm	$F_{v,R}$ kN	l_{min} mm
30	2,91	140	3,52	160				
	1,79	140	2,17	160				
40	3,17	180	4,86	180	6,74	180		
	1,95	180	2,99	180	4,15	180		
50	3,43	220	5,19	220	7,12	220		
	2,11	220	3,20	220	4,38	220		
60	3,54	240	5,53	260	7,50	260		
	2,18	240	3,40	260	4,62	260		
80	3,54	260	5,73	300	8,26	360	10,8	380
	2,18	260	3,52	300	5,08	360	6,66	380
100	3,38	260	6,33	380	8,64	400	11,0	380
	2,08	260	3,89	380	5,32	400	6,78	380
120	3,23	260	7,04	480	9,33	480	12,1	480
	1,98	260	4,33	480	5,74	480	7,45	480
140	3,07	260	7,04	530	9,67	530	11,8	480
	1,89	260	4,33	530	5,95	530	7,28	480
160	2,91	260	7,04	530	10,2	600	13,2	600
	1,79	260	4,33	530	6,30	600	8,12	600
180			7,04	580	10,5	650	12,9	600
			4,33	580	6,43	650	7,95	600
200			7,04	580	10,5	700	12,7	600
			4,33	580	6,43	700	7,79	600
220			7,04	580	10,5	700	12,4	600
			4,33	580	6,43	700	7,62	600
240			6,93	580	10,5	700	12,1	600
			4,26	580	6,43	700	7,45	600
260			6,73	580	10,5	750	11,8	600
			4,14	580	6,43	750	7,28	600
280			6,53	580	10,5	750	11,6	600
			4,02	580	6,43	750	7,11	600
300			6,33	580	10,5	800	11,3	600
			3,89	580	6,43	800	6,94	600

$F_{v,R}$ kN	l_{min} mm
	$F_{v,Rk}$
	$F_{v,Rd}$

General information

ASSY screws are to be pre-drilled for hardwood or Beechwood laminated veneer lumber per ETA-11/0190 Table 1.

Ø	Pre-drilling Ø
5 mm	3.5 mm
6 mm	4 mm
7 mm	5 mm
8 mm	6 mm
10 mm	7 mm
12 mm	8 mm
14 mm	9 mm

Calculation base

- ETA-11/0190
- EN 1995-1-1:2010-12

The exceptions listed in key chapter must be taken into consideration.

NOTE: These represent planning aids. The values are to be measured by authorized persons for a specific project.

SHEAR CAPACITY HARDWOOD/BEECHWOOD LAMINATED VENEER LUMBER/WOOD-WOOD

$\alpha_1 = 90^\circ, \alpha_2 = 0^\circ$ ASSY PLUS VG $\varnothing 14$ MM

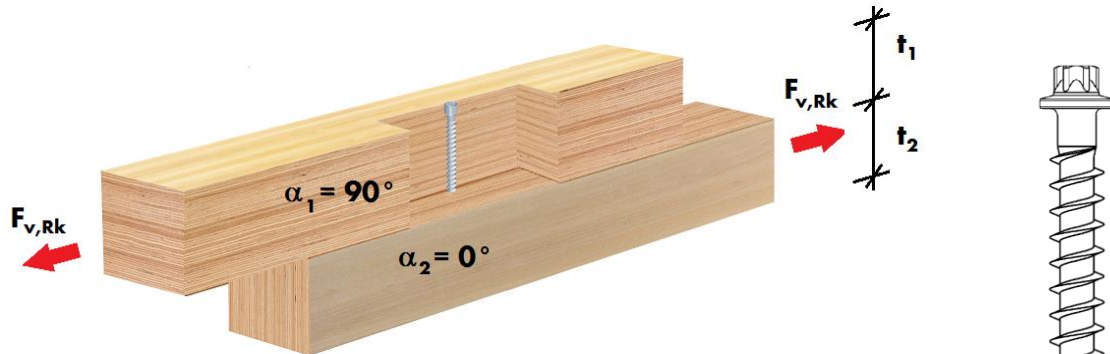

ASSY plus VG $\varnothing 14$ mm - Shear capacity $F_{v,Rk}$ and $F_{v,Rd}$ ($k_{mod} = 0,8$) with required minimum screw length l_{min}

t_1 mm	$\varnothing 14$ mm	
	$F_{v,R}$ kN	l_{min} mm
200	18,7	800
	11,5	800
240	18,7	850
	11,5	850
280	18,7	900
	11,5	900
320	18,7	950
	11,5	950
360	18,7	950
	11,5	950
400	18,7	1000
	11,5	1000
440	18,7	1050
	11,5	1050
480	18,7	1100
	11,5	1100
520	18,7	1200
	11,5	1200
560	18,7	1200
	11,5	1200
600	18,7	1200
	11,5	1200
640	18,7	1300
	11,5	1300
680	18,7	1300
	11,5	1300
720	18,7	1400
	11,5	1400
760	18,7	1400
	11,5	1400
800	18,7	1400
	11,5	1400

$F_{v,R}$ kN	l_{min} mm
	$F_{v,Rk}$
	$F_{v,Rd}$

General information

ASSY screws are to be pre-drilled for hardwood or Beechwood laminated veneer lumber per ETA-11/0190 Table 1.

\varnothing	Pre-drilling \varnothing
5 mm	3.5 mm
6 mm	4 mm
7 mm	5 mm
8 mm	6 mm
10 mm	7 mm
12 mm	8 mm
14 mm	9 mm

Calculation base

- ETA-11/0190
- EN 1995-1-1:2010-12

The exceptions listed in key chapter must be taken into consideration.

NOTE: These represent planning aids. The values are to be measured by authorized persons for a specific project.

WITHDRAWAL CAPACITY HARDWOOD/BEECHWOOD LVL/WOOD-WOOD

$\alpha_1 = 90^\circ, \alpha_2 = 90^\circ$ ASSY 3.0 - ASSY 3.0 ZINI

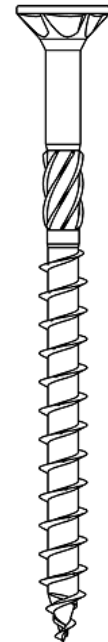
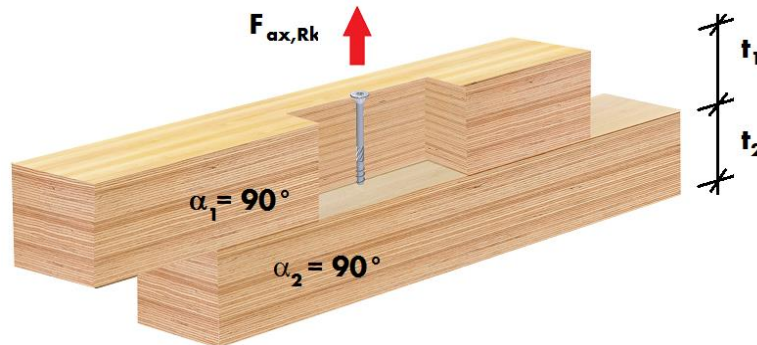

ASSY 3.0 - Withdrawal capacity $F_{ax,Rk}$ and $F_{ax,Rd}$ ($k_{mod} = 0,8$) with required minimum screw length l_{min}

t_1 mm	Ø 5mm		Ø 6mm		Ø 7mm		Ø 8mm		Ø 10mm	
	$F_{ax,R}$ kN	l_{min} mm	$F_{ax,R}$ kN	l_{min} mm	$F_{ax,R}$ kN	l_{min} mm	$F_{ax,R}$ kN	l_{min} mm	$F_{ax,R}$ kN	l_{min} mm
24	1,78	45	2,84	60	3,79	80				
	1,10	45	1,75	60	2,33	80				
30	1,78	50	2,84	60	3,79	80	4,35	80		
	1,10	50	1,75	60	2,33	80	2,68	80		
40	1,78	60	2,84	70	3,79	80	4,35	80	6,54	100
	1,10	60	1,75	70	2,33	80	2,68	80	4,02	100
50	1,82	70	2,84	80	3,79	90	4,35	100	6,54	100
	1,12	70	1,75	80	2,33	90	2,68	100	4,02	100
60	1,82	80	2,84	90	3,79	100	4,35	100	6,54	120
	1,12	80	1,75	90	2,33	100	2,68	100	4,02	120
80	2,00	110	3,14	110	3,79	120	5,35	120	6,54	140
	1,23	110	1,93	110	2,33	120	3,29	120	4,02	140
100	1,82	120	3,14	130	3,79	140	5,35	140	6,54	160
	1,12	120	1,93	130	2,33	140	3,29	140	4,02	160
120			3,14	150	4,89	160	5,35	160	6,54	180
			1,93	150	3,01	160	3,29	160	4,02	180
140			3,14	180	4,89	180	5,35	180	6,54	200
			1,93	180	3,01	180	3,29	180	4,02	200
160			3,14	200	4,89	200	5,35	200	6,54	220
			1,93	200	3,01	200	3,29	200	4,02	220
180			3,14	220	4,89	220	5,35	220	6,54	240
			1,93	220	3,01	220	3,29	220	4,02	240
200			3,14	240	4,89	240	5,35	240	6,54	260
			1,93	240	3,01	240	3,29	240	4,02	260
220			3,14	260	4,89	260	5,35	260	6,54	280
			1,93	260	3,01	260	3,29	260	4,02	280
240			3,14	280	4,89	280	5,35	280	6,54	300
			1,93	280	3,01	280	3,29	280	4,02	300
260			3,14	300	4,89	300	5,35	300	9,11	320
			1,93	300	3,01	300	3,29	300	5,61	320
280							5,35	320	9,11	340
							3,29	320	5,61	340
300							5,35	340	9,11	360
							3,29	340	5,61	360
320							5,35	360	9,11	380
							3,29	360	5,61	380

$F_{v,R}$ kN	l_{min} mm
	$F_{v,Rk}$
	$F_{v,Rd}$

General information

ASSY screws are to be pre-drilled for hardwood or Beechwood laminated veneer lumber per ETA-11/0190 Table 1.

Ø	Pre-drilling Ø
5 mm	3.5 mm
6 mm	4 mm
7 mm	5 mm
8 mm	6 mm
10 mm	7 mm
12 mm	8 mm
14 mm	9 mm

Calculation base

- ETA-11/0190
- EN 1995-1-1:2010-12

The exceptions listed in key chapter must be taken into consideration.

NOTE: These represent planning aids. The values are to be measured by authorized persons for a specific project.

WITHDRAWAL CAPACITY HARDWOOD/BEECHWOOD LVL/WOOD-WOOD

$\alpha_1 = 90^\circ, \alpha_2 = 90^\circ$ ASSY 3.0 SK

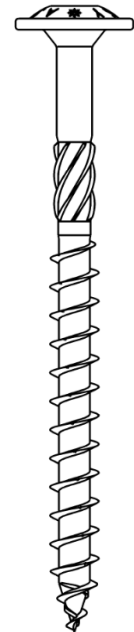
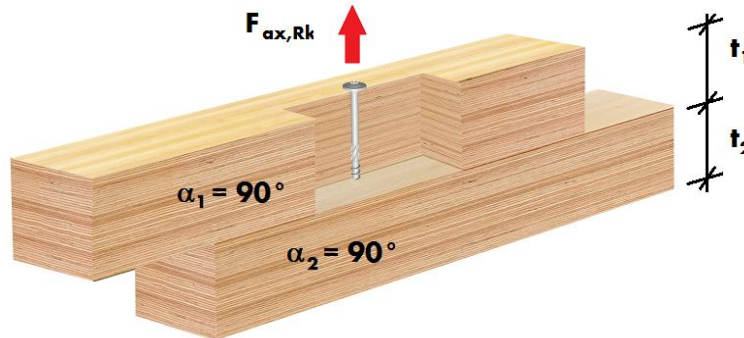

ASSY 3.0 SK - Withdrawal capacity $F_{ax,Rk}$ and $F_{ax,Rd}$ ($k_{mod} = 0,8$) with required minimum screw length l_{min}

t_1 mm	Ø 5mm		Ø 6mm		Ø 8mm		Ø 10mm		Ø 12mm	
	$F_{ax,R}$ kN	l_{min} mm	$F_{ax,R}$ kN	l_{min} mm	$F_{ax,R}$ kN	l_{min} mm	$F_{ax,R}$ kN	l_{min} mm	$F_{ax,R}$ kN	l_{min} mm
24	2,84	60	3,87	70						
	1,75	60	2,38	70						
30	2,84	70	3,87	70	7,35	100				
	1,75	70	2,38	70	4,52	100				
40	2,84	80	3,87	80	7,35	100	9,49	120		
	1,75	80	2,38	80	4,52	100	5,84	120		
50	1,82	70	3,87	90	7,35	120	9,49	120		
	1,12	70	2,38	90	4,52	120	5,84	120		
60	1,82	80	3,87	100	7,35	120	9,49	140		
	1,12	80	2,38	100	4,52	120	5,84	140		
80	2,84	120	3,87	120	7,35	140	6,07	120	12,8	200
	1,75	120	2,38	120	4,52	140	3,74	120	7,86	200
100	1,82	120	3,87	140	7,35	160	9,11	160	12,8	200
	1,12	120	2,38	140	4,52	160	5,61	160	7,86	200
120			3,87	160	7,35	180	9,11	180	12,8	200
			2,38	160	4,52	180	5,61	180	7,86	200
140			3,87	180	7,35	200	9,11	200	12,8	220
			2,38	180	4,52	200	5,61	200	7,86	220
160			3,87	200	7,35	220	9,11	220	10,9	220
			2,38	200	4,52	220	5,61	220	6,73	220
180			3,87	220	7,35	240	9,11	240	10,9	240
			2,38	220	4,52	240	5,61	240	6,73	240
200			3,87	240	7,35	260	9,11	260	10,9	260
			2,38	240	4,52	260	5,61	260	6,73	260
220			3,87	260	7,35	280	9,11	280	10,9	280
			2,38	260	4,52	280	5,61	280	6,73	280
240			3,87	280	7,35	300	9,49	320	10,9	300
			2,38	280	4,52	300	5,84	320	6,73	300
260			3,87	300	7,35	320	9,49	340	10,9	320
			2,38	300	4,52	320	5,84	340	6,73	320
280					7,35	340	9,49	360	10,9	340
					4,52	340	5,84	360	6,73	340
300					7,35	360	9,49	380	12,8	380
					4,52	360	5,84	380	7,86	380
320					7,35	380	9,49	400	12,8	400
					4,52	380	5,84	400	7,86	400

$F_{v,R}$ kN	l_{min} mm
	$F_{v,Rk}$
	$F_{v,Rd}$

General information

ASSY screws are to be pre-drilled for hardwood or Beechwood laminated veneer lumber per ETA-11/0190 Table 1.

Ø	Pre-drilling Ø
5 mm	3.5 mm
6 mm	4 mm
7 mm	5 mm
8 mm	6 mm
10 mm	7 mm
12 mm	8 mm
14 mm	9 mm

Calculation base

- ETA-11/0190
- EN 1995-1-1:2010-12

The exceptions listed in key chapter must be taken into consideration.

NOTE: These represent planning aids. The values are to be measured by authorized persons for a specific project.

WITHDRAWAL CAPACITY HARDWOOD/BEECHWOOD LVL/WOOD-WOOD

$\alpha_1 = 90^\circ, \alpha_2 = 90^\circ$ ASSY 3.0 COMBI

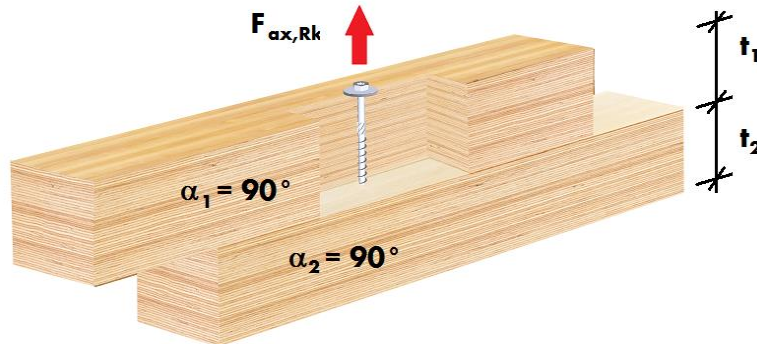

ASSY 3.0 Combi with U-washer - Withdrawal capacity $F_{ax,Rk}$ and $F_{ax,Rd}$ ($k_{mod} = 0,8$) with required minimum screw length l_{min}

t_1 mm	Ø 8/d2 28mm		Ø 10 /d2 34mm		Ø 12 / d2 34mm	
	$F_{ax,R}$ kN	l_{min} mm	$F_{ax,R}$ kN	l_{min} mm	$F_{ax,R}$ kN	l_{min} mm
40	10,7	140	15,2	160		
	6,58	140	9,34	160		
60	13,4	220	15,2	180		
	8,22	220	9,34	180		
80	13,4	220	15,2	200	21,9	220
	8,22	220	9,34	200	13,5	220
100	13,4	220	15,2	220	21,9	240
	8,22	220	9,34	220	13,5	240
120	13,4	240	15,2	240	21,9	260
	8,22	240	9,34	240	13,5	260
140	13,4	260	15,2	260	21,9	280
	8,22	260	9,34	260	13,5	280
160	13,4	280	18,2	320	21,9	300
	8,22	280	11,2	320	13,5	300
180	13,4	300	18,2	320	21,9	320
	8,22	300	11,2	320	13,5	320
200	13,0	300	18,2	340	21,9	340
	7,98	300	11,2	340	13,5	340
220	10,3	300	18,2	360	26,4	380
	6,33	300	11,2	360	16,3	380
240	7,62	300	18,2	380	26,4	400
	4,69	300	11,2	380	16,3	400
260	4,94	300	18,2	400	24,8	400
	3,04	300	11,2	400	15,3	400
280			17,8	400	26,4	440
			10,9	400	16,3	440
300			14,7	400	24,8	440
			9,06	400	15,3	440
320			11,7	400	26,4	480
			7,20	400	16,3	480
340			8,66	400	24,8	480
			5,33	400	15,3	480
360					21,1	480
					13,0	480
380					17,5	480
					10,8	480

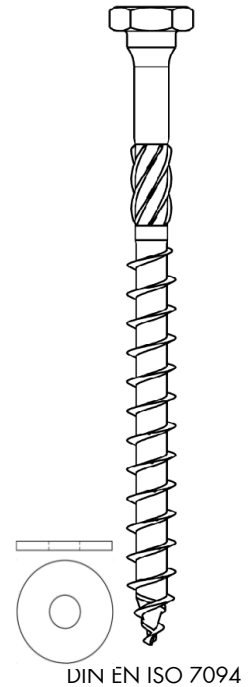

$F_{v,R}$ kN	l_{min} mm
$F_{v,Rk}$	
$F_{v,Rd}$	

General information

ASSY screws are to be pre-drilled for hardwood or Beechwood laminated veneer lumber per ETA-11/0190 Table 1.

Ø	Pre-drilling Ø
5 mm	3,5 mm
6 mm	4 mm
7 mm	5 mm
8 mm	6 mm
10 mm	7 mm
12 mm	8 mm
14 mm	9 mm

Calculation base

- ETA-11/0190
- EN 1995-1-1:2010-12

Penetration resistance corresponding to the bolts per N1995-1-1:2010-12. The exceptions listed in key chapter must be taken into consideration.

NOTE: These represent planning aids. The values are to be measured by authorized persons for a specific project.

WITHDRAWAL CAPACITY HARDWOOD/BEECHWOOD LVL/WOOD-WOOD

$\alpha_1 = 90^\circ, \alpha_2 = 90^\circ$ ASSY PLUS VG

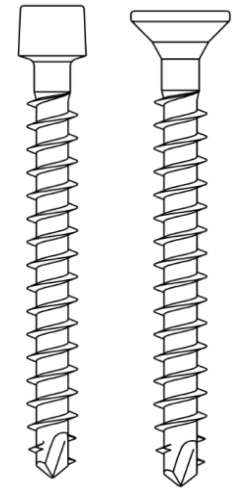
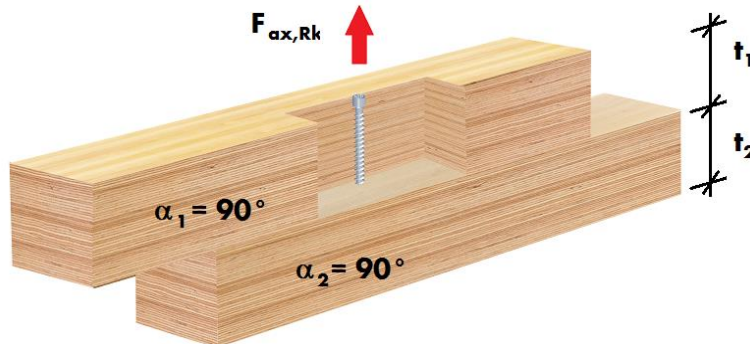

ASSY plus VG - Withdrawal capacity $F_{ax,Rk}$ and $F_{ax,Rd}$ ($k_{mod} = 0,8$) with required minimum screw length l_{min}

t_1 mm	Ø 6mm		Ø 8mm		Ø 10mm		Ø 12mm	
	$F_{ax,R}$ kN	l_{min} mm	$F_{ax,R}$ kN	l_{min} mm	$F_{ax,R}$ kN	l_{min} mm	$F_{ax,R}$ kN	l_{min} mm
30	3,14	80						
	1,93	80						
40	4,19	80	5,35	120	6,07	120		
	2,58	80	3,29	120	3,74	120		
50	5,24	100	6,68	120	7,59	120		
	3,22	100	4,11	120	4,67	120		
60	6,29	120	8,02	120	9,11	120		
	3,87	120	4,93	120	5,61	120		
80	8,38	160	10,7	160	12,1	160	14,6	160
	5,16	160	6,58	160	7,48	160	8,97	160
100	10,5	200	13,4	200	15,2	200	18,2	200
	6,45	200	8,22	200	9,34	200	11,2	200
120	11,0	240	16,0	240	18,2	240	21,9	240
	7,74	240	9,87	240	11,2	240	13,5	240
140	11,0	260	18,7	280	21,3	280	25,5	280
	7,74	260	11,5	280	13,1	280	15,7	280
160	10,5	260	20,0	330	24,3	320	29,2	380
	6,45	260	13,2	330	15,0	320	17,9	380
180	8,38	260	20,0	330	27,3	360	32,8	380
	5,16	260	14,8	380	16,8	360	20,2	380
200	6,29	260	20,0	380	30,4	400	36,4	480
	3,87	260	15,4	430	18,7	400	22,4	480
220	4,19	260	20,0	380	32,0	480	40,1	480
	2,58	260	15,4	430	20,6	480	24,7	480
240			20,0	430	32,0	480	43,7	480
			15,4	430	22,4	480	26,9	480
260			20,0	430	32,0	480	45,0	600
			15,4	480	24,3	530	29,2	600
280			20,0	430	32,0	530	45,0	600
			15,4	480	24,6	580	31,4	600
300			20,0	480	32,0	530	45,0	600
			15,4	530	24,6	580	33,6	600

$F_{v,R}$ kN	l_{min} mm
	$F_{v,Rk}$
	$F_{v,Rd}$

General information

ASSY screws are to be pre-drilled for hardwood or Beechwood laminated veneer lumber per ETA-11/0190 Table 1.

Ø	Pre-drilling Ø
5 mm	3,5 mm
6 mm	4 mm
7 mm	5 mm
8 mm	6 mm
10 mm	7 mm
12 mm	8 mm
14 mm	9 mm

Calculation base

- ETA-11/0190
- EN 1995-1-1:2010-12

The exceptions listed in key chapter must be taken into consideration.

NOTE: These represent planning aids. The values are to be measured by authorized persons for a specific project.

WITHDRAWAL CAPACITY HARDWOOD/BEECHWOOD LVL/WOOD-WOOD

$\alpha_1 = 90^\circ, \alpha_2 = 90^\circ$ ASSY PLUS VG $\varnothing 14$ MM

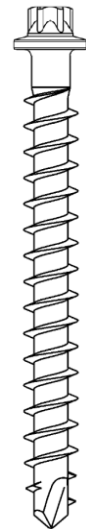
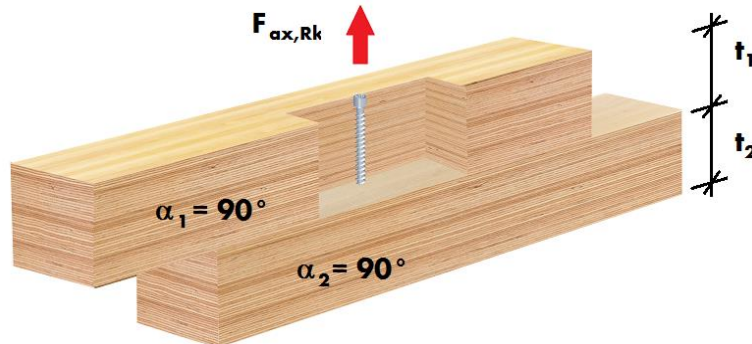

ASSY plus VG $\varnothing 14$ mm - Withdrawal capacity $F_{ax,Rk}$ and $F_{ax,Rd}$ ($k_{mod} = 0,8$) with required minimum screw length l_{min}

t_1 mm	$\varnothing 14$ mm	
	$F_{ax,R}$ kN	l_{min} mm
200	42,5	400
	26,2	400
240	51,0	800
	31,4	800
280	59,5	800
	36,6	800
320	62,0	800
	41,9	800
360	62,0	800
	47,1	800
400	62,0	800
	47,7	800
440	62,0	800
	47,7	850
480	62,0	800
	47,7	850
520	62,0	850
	47,7	900
560	62,0	900
	47,7	950
600	62,0	900
	47,7	1000
640	62,0	950
	47,7	1050
680	62,0	1000
	47,7	1050
720	62,0	1050
	47,7	1100
760	62,0	1100
	47,7	1200
800	62,0	1100
	47,7	1200

$F_{v,R}$ kN	l_{min} mm
	$F_{v,Rk}$
	$F_{v,Rd}$

General information

ASSY screws are to be pre-drilled for hardwood or Beechwood laminated veneer lumber per ETA-11/0190 Table 1.

\varnothing	Pre-drilling \varnothing
5 mm	3.5 mm
6 mm	4 mm
7 mm	5 mm
8 mm	6 mm
10 mm	7 mm
12 mm	8 mm
14 mm	9 mm

Calculation base

- ETA-11/0190
- EN 1995-1-1:2010-12

The exceptions listed in key chapter must be taken into consideration.

NOTE: These represent planning aids. The values are to be measured by authorized persons for a specific project.

WITHDRAWAL HARDWOOD/BEECHWOOD LAMINATED VENEER LUMBER/WOOD-WOOD

$\alpha_1 = 90^\circ, \alpha_2 = 0^\circ$ ASSY 3.0 - ASSY 3.0 ZINI

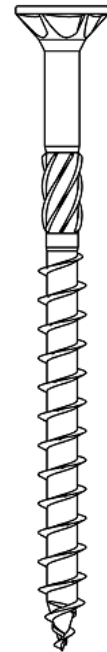
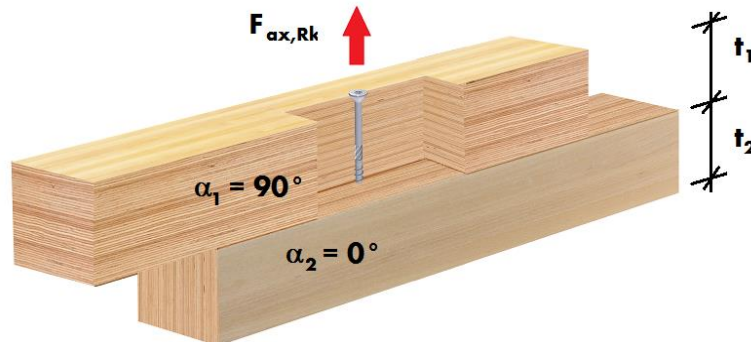

ASSY 3.0 - Withdrawal capacity $F_{ax,Rk}$ and $F_{ax,Rd}$ ($k_{mod} = 0,8$) with required minimum screw length l_{min}

t_1 mm	Ø 5mm		Ø 6mm		Ø 7mm		Ø 8mm		Ø 10mm	
	$F_{ax,R}$ kN	l_{min} mm	$F_{ax,R}$ kN	l_{min} mm	$F_{ax,R}$ kN	l_{min} mm	$F_{ax,R}$ kN	l_{min} mm	$F_{ax,R}$ kN	l_{min} mm
24			2,20	180	3,12	200				
			1,35	180	1,92	200				
30			2,20	180	3,12	200	4,01	240		
			1,35	180	1,92	200	2,47	240		
40			2,20	200	3,12	220	4,01	240	5,47	320
			1,35	200	1,92	220	2,47	240	3,36	320
50			2,20	200	3,12	220	4,01	260	5,47	320
			1,35	200	1,92	220	2,47	260	3,36	320
60			2,20	220	3,12	240	4,01	260	5,47	320
			1,35	220	1,92	240	2,47	260	3,36	320
80			2,20	240	3,12	260	4,01	280	5,47	320
			1,35	240	1,92	260	2,47	280	3,36	320
100			2,20	260	3,12	280	4,01	300	5,47	340
			1,35	260	1,92	280	2,47	300	3,36	340
120			2,20	280	3,12	300	4,01	320	5,47	360
			1,35	280	1,92	300	2,47	320	3,36	360
140			2,20	300			4,01	340	5,47	380
			1,35	300			2,47	340	3,36	380
160							4,01	360	5,47	400
							2,47	360	3,36	400
180							4,01	380		
							2,47	380		
200							4,01	400		
							2,47	400		
220										
240										
260										
280										
300										
320										

$F_{v,R}$ kN	l_{min} mm
	$F_{v,Rk}$
	$F_{v,Rd}$

General information

ASSY screws are to be pre-drilled for hardwood or Beechwood laminated veneer lumber per ETA-11/0190 Table 1.

Ø	Pre-drilling Ø
5 mm	3.5 mm
6 mm	4 mm
7 mm	5 mm
8 mm	6 mm
10 mm	7 mm
12 mm	8 mm
14 mm	9 mm

Calculation base

- ETA-11/0190
- EN 1995-1-1:2010-12

The exceptions listed in key chapter must be taken into consideration.

NOTE: These represent planning aids. The values are to be measured by authorized persons for a specific project.

WITHDRAWAL CAPACITY HARDWOOD/BEECHWOOD LVL/WOOD-WOOD

$\alpha_1 = 90^\circ, \alpha_2 = 0^\circ$ ASSY 3.0 SK

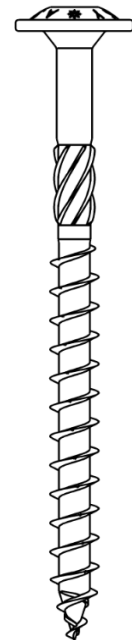
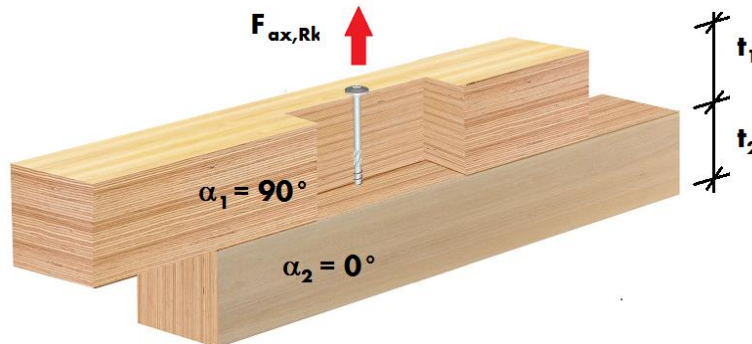

ASSY 3.0 SK - Withdrawal capacity $F_{ax,Rk}$ and $F_{ax,Rd}$ ($k_{mod} = 0,8$) with required minimum screw length l_{min}

t_1 mm	Ø 5mm		Ø 6mm		Ø 8mm		Ø 10mm		Ø 12mm	
	$F_{ax,R}$ kN	l_{min} mm	$F_{ax,R}$ kN	l_{min} mm	$F_{ax,R}$ kN	l_{min} mm	$F_{ax,R}$ kN	l_{min} mm	$F_{ax,R}$ kN	l_{min} mm
24			2,20	180						
			1,35	180						
30			2,20	180	4,01	240				
			1,35	180	2,47	240				
40			2,20	200	4,01	240	5,47	320		
			1,35	200	2,47	240	3,36	320		
50			2,20	200	4,01	260	5,47	320		
			1,35	200	2,47	260	3,36	320		
60			2,20	220	4,01	260	5,47	320		
			1,35	220	2,47	260	3,36	320		
80			2,20	240	4,01	280	5,47	320	7,93	380
			1,35	240	2,47	280	3,36	320	4,88	380
100			2,20	260	4,01	300	5,47	340	7,93	400
			1,35	260	2,47	300	3,36	340	4,88	400
120			2,20	280	4,01	320	5,47	360	7,93	440
			1,35	280	2,47	320	3,36	360	4,88	440
140			2,20	300	4,01	340	5,47	380	7,93	440
			1,35	300	2,47	340	3,36	380	4,88	440
160					4,01	360	5,47	400	7,93	480
					2,47	360	3,36	400	4,88	480
180					4,01	380	5,47	420	7,93	480
					2,47	380	3,36	420	4,88	480
200					4,01	400	5,47	440	7,93	520
					2,47	400	3,36	440	4,88	520
220					4,01	420	5,47	460	7,93	520
					2,47	420	3,36	460	4,88	520
240					4,01	440	5,47	480		
					2,47	440	3,36	480		
260					4,01	460	5,47	500		
					2,47	460	3,36	500		
280					4,01	480				
					2,47	480				
300					4,01	500				
					2,47	500				
320					4,01	520				
					2,47	520				

$F_{v,R}$ kN	l_{min} mm
	$F_{v,Rk}$
	$F_{v,Rd}$

General information

ASSY screws are to be pre-drilled for hardwood or Beechwood laminated veneer lumber per ETA-11/0190 Table 1.

Ø	Pre-drilling Ø
5 mm	3.5 mm
6 mm	4 mm
7 mm	5 mm
8 mm	6 mm
10 mm	7 mm
12 mm	8 mm
14 mm	9 mm

Calculation base

- ETA-11/0190
- EN 1995-1-1:2010-12

The exceptions listed in key chapter must be taken into consideration.

NOTE: These represent planning aids. The values are to be measured by authorized persons for a specific project.

WITHDRAWAL CAPACITY HARDWOOD/BEECHWOOD LVL/WOOD-WOOD

$\alpha_1 = 90^\circ, \alpha_2 = 0^\circ$ ASSY 3.0 COMBI

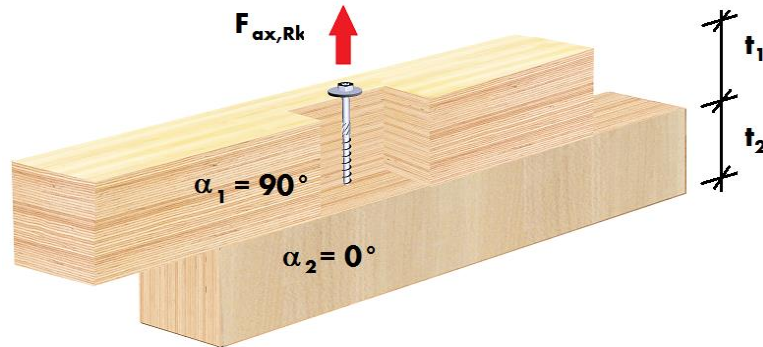

ASSY 3.0 Combi and U-washer - Withdrawal capacity $F_{ax,Rk}$ and $F_{ax,Rd}$ ($k_{mod} = 0,8$) with required minimum screw length l_{min}

t_1 mm	Ø 8/d2 28mm		Ø 10 /d2 34mm		Ø 12 / d2 34mm	
	$F_{ax,R}$ kN	l_{min} mm	$F_{ax,R}$ kN	l_{min} mm	$F_{ax,R}$ kN	l_{min} mm
40	4,01	240	5,47	320		
	2,47	240	3,36	320		
60	4,01	260	5,47	320		
	2,47	260	3,36	320		
80	4,01	280	5,47	340	7,93	380
	2,47	280	3,36	340	4,88	380
100	4,01	300	5,47	360	7,93	400
	2,47	300	3,36	360	4,88	400
120			5,47	380	7,93	440
			3,36	380	4,88	440
140			5,47	400	7,93	440
			3,36	400	4,88	440
160					7,93	480
					4,88	480
180					7,93	480
					4,88	480
200						
220						
240						
260						
280						
300						
320						
340						
360						
380						

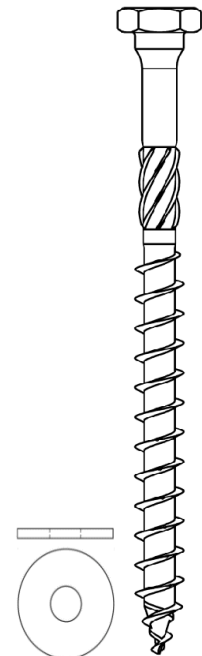

DIN EN ISO 7094

$F_{v,R}$ kN	l_{min} mm
	$F_{v,Rk}$
	$F_{v,Rd}$

General information

ASSY screws are to be pre-drilled for hardwood or Beechwood laminated veneer lumber per ETA-11/0190 Table 1.

Ø	Pre-drilling Ø
5 mm	3.5 mm
6 mm	4 mm
7 mm	5 mm
8 mm	6 mm
10 mm	7 mm
12 mm	8 mm
14 mm	9 mm

Calculation base

- ETA-11/0190,
- EN 1995-1-1:2010-12

Penetration resistance corresponding to the bolts per N1995-1-1:2010-12. The exceptions listed in key chapter must be taken into consideration.

NOTE: These represent planning aids. The values are to be measured by authorized persons for a specific project.

WITHDRAWAL CAPACITY HARDWOOD/BEECHWOOD LVL/WOOD-WOOD

$\alpha_1 = 90^\circ$, $\alpha_2 = 0^\circ$ ASSY PLUS VG

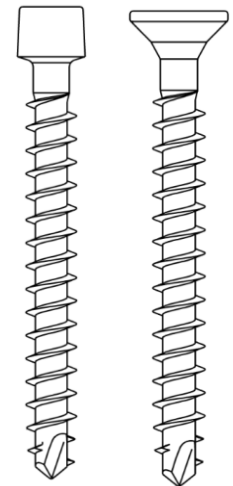
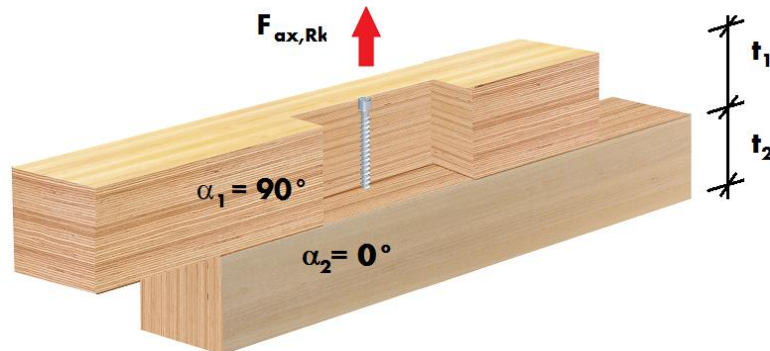

ASSY plus VG - Withdrawal capacity $F_{ax,Rk}$ and $F_{ax,Rd}$ ($k_{mod} = 0,8$) with required minimum screw length l_{min}

t_1 mm	Ø 6mm		Ø 8mm		Ø 10mm		Ø 12mm	
	$F_{ax,R}$ kN	l_{min} mm	$F_{ax,R}$ kN	l_{min} mm	$F_{ax,R}$ kN	l_{min} mm	$F_{ax,R}$ kN	l_{min} mm
30	3,14	180						
	1,93	180						
40	4,19	200	5,35	240	6,07	280		
	2,58	200	3,29	240	3,74	280		
50	5,24	220	6,68	260	7,59	300		
	3,22	220	4,11	260	4,67	300		
60	5,66	240	8,02	260	9,11	300		
	3,48	240	4,93	260	5,61	300		
80	5,66	260	8,82	300	12,1	360	14,6	380
	3,48	260	5,43	300	7,48	360	8,97	380
100	5,03	260	11,2	380	13,7	400	18,2	480
	3,10	260	6,91	380	8,41	400	11,2	480
120			14,4	480	16,4	480	19,7	480
			8,88	480	10,1	480	12,1	480
140			15,6	530	17,8	530	18,6	480
			9,62	530	10,9	530	11,4	480
160			16,8	580	20,0	600	24,1	600
			10,4	580	12,3	600	14,8	600
180			16,0	580	23,7	700	23,0	600
			9,87	580	14,6	700	14,1	600
200			15,2	580	27,3	800	21,9	600
			9,37	580	16,8	800	13,5	600
220			14,4	580	26,4	800	20,8	600
			8,88	580	16,3	800	12,8	600
240			13,6	580	25,5	800	19,7	600
			8,39	580	15,7	800	12,1	600
260			12,8	580	24,6	800	18,6	600
			7,89	580	15,1	800	11,4	600
280			12,0	580	23,7	800	17,5	600
			7,40	580	14,6	800	10,8	600
300			11,2	580	22,8	800	16,4	600
			6,91	580	14,0	800	10,1	600

$F_{v,R}$ kN	l_{min} mm
	$F_{v,Rk}$
	$F_{v,Rd}$

General information

ASSY screws are to be pre-drilled for hardwood or Beechwood laminated veneer lumber per ETA-11/0190 Table 1.

Ø	Pre-drilling Ø
5 mm	3,5 mm
6 mm	4 mm
7 mm	5 mm
8 mm	6 mm
10 mm	7 mm
12 mm	8 mm
14 mm	9 mm

Calculation base

- ETA-11/0190
- EN 1995-1-1:2010-12

The exceptions listed in key chapter must be taken into consideration.

NOTE: These represent planning aids. The values are to be measured by authorized persons for a specific project.

WITHDRAWAL CAPACITY HARDWOOD/BEECHWOOD LVL/WOOD-WOOD

$\alpha_1 = 90^\circ, \alpha_2 = 0^\circ$ ASSY PLUS VG $\varnothing 14$ MM

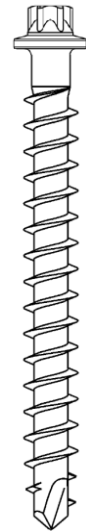
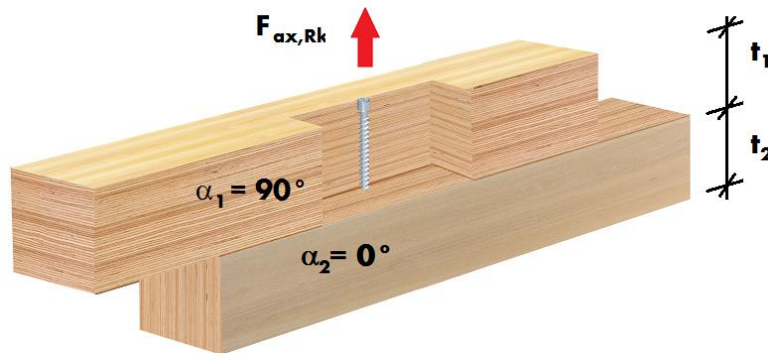

ASSY plus VG $\varnothing 14$ mm - Withdrawal capacity $F_{ax,Rk}$ and $F_{ax,Rd}$ ($k_{mod} = 0,8$) with required minimum screw length l_{min}

t_1 mm	$\varnothing 14$ mm	
	$F_{ax,R}$ kN	l_{min} mm
200	38,3	800
	23,5	800
240	45,3	950
	27,9	950
280	52,3	1100
	32,2	1100
320	56,1	1200
	34,5	1200
360	62,0	1400
	39,2	1400
400	62,0	1400
	39,2	1400
440	62,0	1500
	39,2	1500
480	62,0	1500
	39,2	1500
520	62,0	1500
	38,5	1500
560	60,0	1500
	36,9	1500
600	57,4	1500
	35,3	1500
640	54,8	1500
	33,8	1500
680	52,3	1500
	32,2	1500
720	49,7	1500
	30,6	1500
760	47,2	1500
	29,0	1500
800	44,6	1500
	27,5	1500

$F_{v,R}$ kN	l_{min} mm
	$F_{v,Rk}$
	$F_{v,Rd}$

General information

ASSY screws are to be pre-drilled for hardwood or Beechwood laminated veneer lumber per ETA-11/0190 Table 1.

\varnothing	Pre-drilling \varnothing
5 mm	3.5 mm
6 mm	4 mm
7 mm	5 mm
8 mm	6 mm
10 mm	7 mm
12 mm	8 mm
14 mm	9 mm

Calculation base

- ETA-11/0190
- EN 1995-1-1:2010-12

The exceptions listed in key chapter must be taken into consideration.

NOTE: These represent planning aids. The values are to be measured by authorized persons for a specific project.

LAP SHEAR HARDWOOD/BEECHWOOD LAMINATED VENEER LUMBER/WOOD-WOOD

$\alpha_1 = 45^\circ, \alpha_2 = 45^\circ$ ASSY PLUS VG

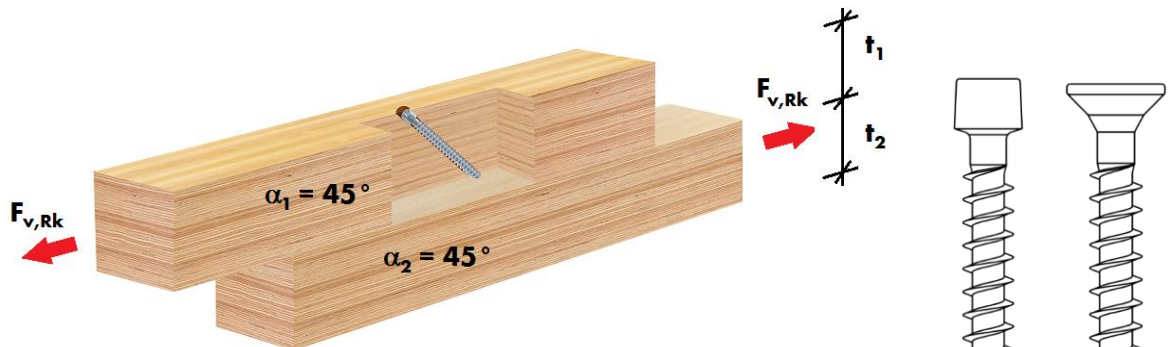

ASSY plus VG - Lap shear capacity $F_{v,Rk}$ and $F_{v,Rd}$ ($k_{mod} = 0,8$ and $\gamma_M = 1,3$) with required minimum screw length l_{min}

t_1	Ø 6mm		Ø 8mm		Ø 10mm		Ø 12mm	
	$F_{v,R}$ kN	l_{min} mm	$F_{v,R}$ kN	l_{min} mm	$F_{v,R}$ kN	l_{min} mm	$F_{v,R}$ kN	l_{min} mm
30	3,14	100	4,01	120				
	1,93	100	2,47	120				
40	4,19	120	5,35	120	6,07	120		
	2,58	120	3,29	120	3,74	120		
50	5,24	160	6,68	160	7,59	160		
	3,22	160	4,11	160	4,67	160		
60	6,29	180	8,02	180	9,11	180		
	3,87	180	4,93	180	5,61	180		
80	7,78	220	10,7	240	12,1	240	14,6	240
	5,16	240	6,58	240	7,48	240	8,97	240
100	7,78	260	13,4	300	15,2	300	18,2	300
	5,41	260	8,22	300	9,34	300	11,2	300
120	6,69	260	14,1	330	18,2	340	21,9	380
	4,12	260	9,87	380	11,2	340	13,5	380
140	4,59	260	14,1	380	21,3	400	25,5	480
	2,83	260	10,9	430	13,1	400	15,7	480
160	2,50	260	14,1	380	22,6	480	29,2	480
	1,54	260	10,9	430	15,0	480	17,9	480
180			14,1	430	22,6	480	31,8	600
			10,9	480	16,8	530	20,2	600
200			14,1	480	22,6	530	31,8	600
			10,9	480	17,4	580	22,4	600
220			14,1	480	22,6	530	31,8	600
			10,9	530	17,4	580	22,9	600
240			14,1	530	22,6	580	31,8	600
			10,9	530	17,4	650	20,7	600
260			14,1	530	22,6	580	29,9	600
			10,9	580	17,4	650	18,4	600
280			14,1	580	22,6	650	26,3	600
			10,7	580	17,4	700	16,2	600
300			14,1	580	22,6	650	22,6	600
			9,06	580	17,4	700	13,9	600

$F_{v,R}$ kN	l_{min} mm
	$F_{v,Rk}$
	$F_{v,Rd}$

General information

ASSY screws are to be pre-drilled for hardwood or Beechwood laminated veneer lumber per ETA-11/0190 Table 1.

Ø	Pre-drilling Ø
5 mm	3.5 mm
6 mm	4 mm
7 mm	5 mm
8 mm	6 mm
10 mm	7 mm
12 mm	8 mm
14 mm	9 mm

Calculation base

- ETA-11/0190
- EN 1995-1-1:2010-12

The exceptions listed in key chapter must be taken into consideration.

NOTE: The value for shear capacity F_v can be multiplied by 1.25 if friction between the two components is to be estimated. In the case of connections using multiple screws, the effective number of screws n_{ef} per DIN EN 1995-1-1 (8.17) and/or ETA-11/0190 A.1.3.1 must be adhered to.

NOTE: These represent planning aids. The values are to be measured by authorized persons for a specific project.

LAP SHEAR HARDWOOD/BEECHWOOD LAMINATED VENEER LUMBER/WOOD-WOOD

$\alpha_1 = 45^\circ, \alpha_2 = 45^\circ$ ASSY PLUS VG $\varnothing 14$ MM

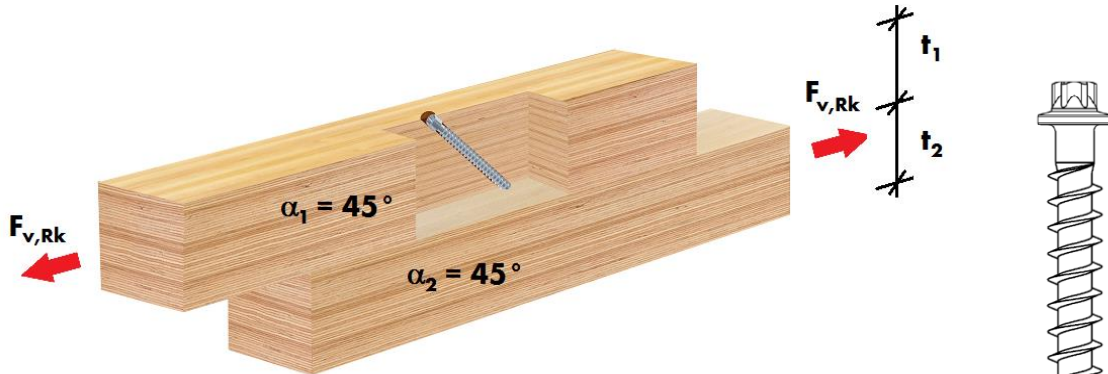

ASSY plus VG $\varnothing 14$ mm - Lap shear capacity $F_{v,R}$ and $F_{v,Rd}$ ($k_{mod} = 0,8$ and $\gamma_M = 1,3$) with required minimum screw length l_{min}

t_1 mm	$\varnothing 14$ mm	
	$F_{v,R}$ kN	l_{min} mm
200	42,5	800
	26,2	800
240	43,8	800
	31,4	800
280	43,8	800
	33,7	800
320	43,8	800
	33,7	850
360	43,8	850
	33,7	900
400	43,8	900
	33,7	950
440	43,8	950
	33,7	1000
480	43,8	1000
	33,7	1050
520	43,8	1050
	33,7	1100
560	43,8	1100
	33,7	1200
600	43,8	1200
	33,7	1300
640	43,8	1200
	33,7	1300
680	43,8	1300
	33,7	1400
720	43,8	1400
	33,7	1400
760	43,8	1400
	33,7	1500
800	43,8	1500
	33,7	1500

NOTE: The value for shear capacity F_v can be multiplied by 1.25 if friction between the two components is to be estimated. In the case of connections using multiple screws, the effective number of screws n_{ef} per DIN EN 1995-1-1 (8.17) and/or ETA-11/0190 A.1.3.1 must be adhered to.

NOTE: These represent planning aids. The values are to be measured by authorized persons for a specific project.

$F_{v,R}$ kN	l_{min} mm
	$F_{v,Rk}$
	$F_{v,Rd}$

General information

ASSY screws are to be pre-drilled for hardwood or Beechwood laminated veneer lumber per ETA-11/0190 Table 1.

\varnothing	Pre-drilling \varnothing
5 mm	3.5 mm
6 mm	4 mm
7 mm	5 mm
8 mm	6 mm
10 mm	7 mm
12 mm	8 mm
14 mm	9 mm

Calculation base

- ETA-11/0190
- EN 1995-1-1:2010-12

The exceptions listed in key chapter must be taken into consideration.

WITHDRAWAL LOAD CAPACITY FROM HARDWOOD/BEECHWOOD LAMINATED VENEER LUMBER

$\alpha = 90^\circ$ ASSY PLUS VG

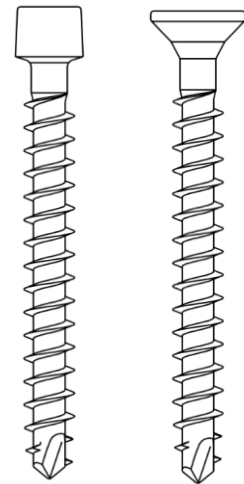
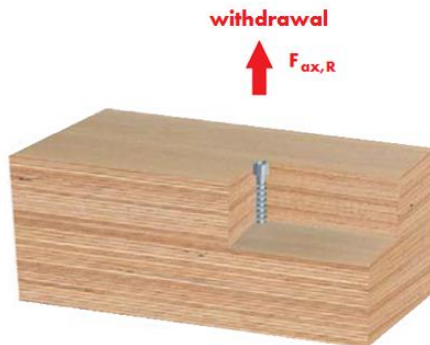

ASSY plus VG - Withdrawal load capacity $F_{ax,Rk}$ and $F_{ax,Rd}$
 ($k_{mod} = 0,8$) in kN per cm anchorage length

t_1 Degrees	Ø 6mm kN	Ø 8mm kN	Ø 10mm kN	Ø 12mm kN	Ø 14mm* kN
90° - 45°	1,05	1,34	1,52	1,82	2,13
	0,64	0,82	0,93	1,12	1,31
40°	0,97	1,23	1,40	1,68	1,96
	0,59	0,76	0,86	1,03	1,21
35°	0,88	1,13	1,28	1,54	1,80
	0,54	0,69	0,79	0,95	1,10
30°	0,80	1,02	1,16	1,40	1,63
	0,49	0,63	0,72	0,86	1,00
25°	0,72	0,92	1,05	1,26	1,46
	0,44	0,57	0,64	0,77	0,90
20°	0,64	0,82	0,93	1,11	1,30
	0,39	0,50	0,57	0,69	0,80
15°	0,56	0,71	0,81	0,97	1,13
	0,34	0,44	0,50	0,60	0,70
10°	0,48	0,61	0,69	0,83	0,97
	0,29	0,37	0,43	0,51	0,60
5°	0,40	0,50	0,57	0,69	0,80
	0,24	0,31	0,35	0,42	0,49
0°	0,31	0,40	0,46	0,55	0,64
	0,19	0,25	0,28	0,34	0,39

Ø 6mm
kN
$F_{ax,Rk}$
$F_{ax,Rd}$

General information

ASSY screws are to be pre-drilled for hardwood or Beechwood laminated veneer lumber per ETA-11/0190 Table 1.

Ø	Pre-drilling Ø
5 mm	3.5 mm
6 mm	4 mm
7 mm	5 mm
8 mm	6 mm
10 mm	7 mm
12 mm	8 mm
14 mm	9 mm

Calculation base

- ETA-11/0190
- EN 1995-1-1:2010-12

Key

- α = Angle between screw axis and direction of the grain
 $F_{ax,R}$ = Load capacity of a screw for thread withdrawal
 $F_{ax,Rk}$ = min. {Table value $\times l_{ef}$; F_{tens} }
 l_{ef} = Effective anchorage length of the threads in cm
 F_{tens} = Load capacity for tearing out
- | | |
|----------------|----------------------|
| $F_{tens,k}$ = | $F_{tens,d}$ = |
| 11,0 kN | 8,46 kN for Ø 6 mm |
| 20,0 kN | 15,4 kN for Ø 8 mm |
| 32,0 kN | 24,6 kN for Ø 10 mm |
| 45,0 kN | 34,6 kN for Ø 12 mm |
| 62,0 kN | 47,7 kN for Ø 14 mm* |

*Values do not apply to hot-dip galvanized screws

Load capacities apply to a characteristic density $\rho_k \geq 680 \text{ kg/m}^3$

Rated value for load capacity with $k_{mod} = 0,8$ and $\gamma_M = 1,3$

NOTE: These represent planning aids. The values are to be measured by authorized persons for a specific project.

PRESSURE BEARING CAPACITY IN HARDWOOD/BEECHWOOD LAMINATED VENEER LUMBER

$\alpha = 90^\circ$ ASSY PLUS VG

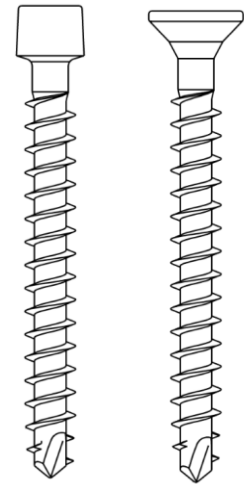
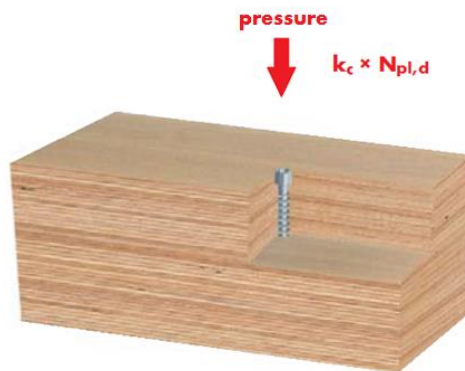

ASSY plus VG - Rated value for maximum compressive load capacity $k_c \times N_{pl,d}$ in kN

α Degrees	Ø 6mm kN	Ø 8mm kN	Ø 10mm kN	Ø 12mm kN	Ø 14mm* kN
90°	7,08	12,4	19,4	25,7	37,3
85°	7,04	12,4	19,3	25,6	37,1
80°	7,01	12,3	19,2	25,5	36,9
75°	6,97	12,3	19,1	25,4	36,8
70°	6,93	12,2	19,0	25,2	36,6
65°	6,89	12,1	18,9	25,1	36,4
60°	6,85	12,1	18,8	25,0	36,2
55°	6,80	12,0	18,7	24,8	36,0
50°	6,76	11,9	18,6	24,7	35,8
45°	6,71	11,8	18,4	24,5	35,6
40°	6,66	11,7	18,3	24,4	35,3
35°	6,61	11,6	18,2	24,2	35,1
30°	6,55	11,6	18,0	24,0	34,8
25°	6,49	11,5	17,9	23,8	34,6
20°	6,43	11,4	17,7	23,6	34,3
15°	6,37	11,2	17,6	23,4	34,0
10°	6,30	11,1	17,4	23,2	33,7
5°	6,23	11,0	17,2	22,9	33,3
0°	6,15	10,9	17,0	22,7	33,0

General information

ASSY screws are to be pre-drilled for hardwood or Beechwood laminated veneer lumber per ETA-11/0190 Table 1.

Ø	Pre-drilling Ø
5 mm	3.5 mm
6 mm	4 mm
7 mm	5 mm
8 mm	6 mm
10 mm	7 mm
12 mm	8 mm
14 mm	9 mm

Calculation base

- ETA-11/0190
- EN 1995-1-1:2010-12

Key

- $k_c \times N_{pl,d}$ Rated value per the max. load capacity of a screw under pressure
- α = Angle between screw axis and direction of the grain
- $F_{ax,Rd}$ = $\min \{k_{mod} / \gamma_M \times F_{ax,Rk}; K_c \times N_{pl,d}\}$
- $F_{ax,Rk}$ = Characteristic value for withdrawal capacity of the threads depending on thread reach

*Values do not apply to hot-dip galvanized screws
Load capacities apply to a characteristic density $\rho_k \geq 680 \text{ kg/m}^3$

NOTE: These represent planning aids. The values are to be measured by authorized persons for a specific project.

MAIN/SIDE BAR/BEECHWOOD LAMINATED VENEER LUMBER CONNECTION CROSSED ASSY PLUS VG, $\beta = 45^\circ$

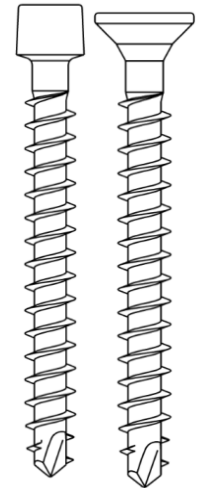
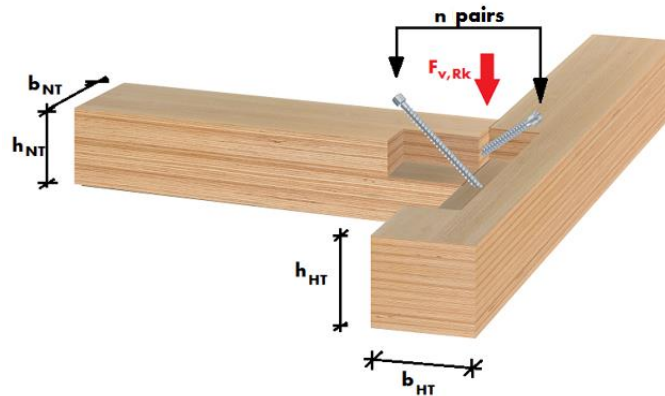

ASSY plus VG - Main and supporting beam connection

d x l mm	Screw pairs	F _{Rk} kN	F _{Rd} kN	min b _{NT} mm	min h _{NT} mm	min b _{HT} mm	min h _{HT} mm	m mm
6 x 140	1	6,78	4,17	45	99	49	99	49
	2	12,6	7,78	75				
6 x 160	1	9,74	6	45	113	57	113	57
	2	18,2	11,2	75				
6 x 180	1	10,1	7,78	45	127	64	127	64
	2	18,9	14,5	75				
6 x 200	1	10,1	8,69	45	141	71	141	71
	2	18,9	16,2	75				
6 x 220	1	10,1	9,22	45	156	78	156	78
	2	18,9	17,2	75				
8 x 200	1	9,8	8,36	60	141	71	141	71
	2	18,3	15,6	100				
8 x 220	1	13,6	10,7	60	156	78	156	78
	2	25,3	19,9	100				
8 x 240	1	17,4	13	60	170	85	170	85
	2	32,4	24,3	100				
8 x 260	1	17,9	14,2	60	184	92	184	92
	2	33,4	26,6	100				
8 x 280	1	17,9	15,4	60	198	99	198	99
	2	33,4	28,8	100				
8 x 300	1	17,9	16,3	60	212	106	212	106
	2	33,4	30,3	100				
10 x 240	1	17,7	10,9	75	170	85	170	85
	2	33,1	20,4	125				
10 x 260	1	22	13,6	75	184	92	184	92
	2	41,1	25,3	125				
10 x 280	1	26,3	16,2	75	198	99	198	99
	2	49,1	30,2	125				
10 x 300	1	27,9	18,8	75	212	106	212	106
	2	52,1	35	125				
10 x 320	1	27,9	20,1	75	226	113	226	113
	2	52,1	37,5	125				
10 x 340	1	27,9	21,4	75	240	120	240	120
	2	52,1	40	125				
10 x 360	1	27,9	22,7	75	255	127	255	127
	2	52,1	42,4	125				
10 x 380	1	27,9	24,1	75	269	134	269	134
	2	52,1	44,9	125				
10 x 400	1	27,9	25,4	75	283	141	283	141
	2	52,1	47,3	115				
12 x 300	1	28,6	17,6	90	212	106	212	106
	2	53,4	32,9	150				
12 x 380	1	37,2	28,6	90	269	134	269	134
	2	69,3	53,4	150				
12 x 400	1	37,2	33,8	90	339	170	339	170
	2	69,3	63	138				

General information

ASSY screws are to be pre-drilled for hardwood or Beechwood laminated veneer lumber per ETA-11/0190 Table 1.

Ø	Pre-drilling Ø
5 mm	3.5 mm
6 mm	4 mm
7 mm	5 mm
8 mm	6 mm
10 mm	7 mm
12 mm	8 mm
14 mm	9 mm

Calculation base

- ETA-11/0190
- EN 1995-1-1:2010-12

The exceptions listed in key chapter must be taken into consideration.

NOTE: These represent planning aids. The values are to be measured by authorized persons for a specific project.

MAIN - SIDE BAR CONNECTION WITH ASSY® PLUS VG SCREWS STEEL - HARDWOOD / BEECHWOOD LAMINATED VENEER LUMBER

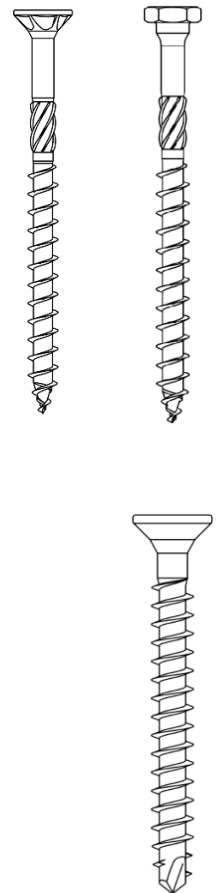
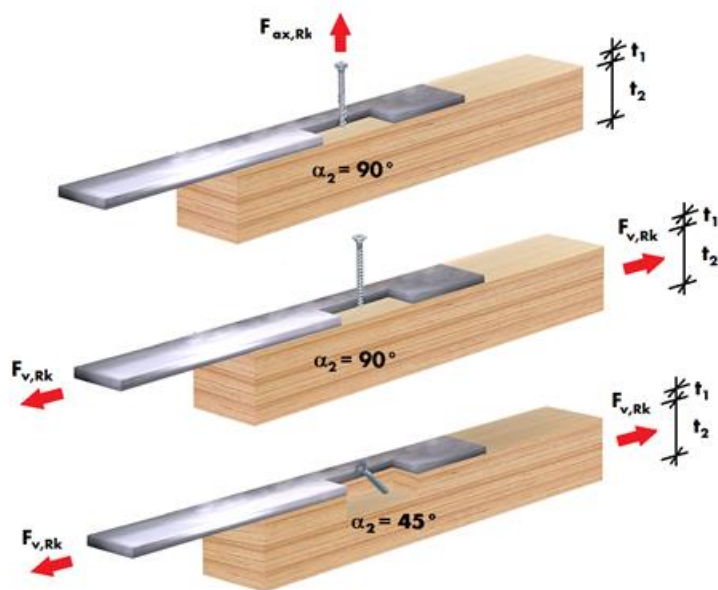

NOTE: These represent planning aids. The values are to be measured by authorized persons for a specific project.

USES FOR HARDWOOD/BEECHWOOD LAMINATED VENEER LUMBER/STEEL-WOOD SHEAR CONNECTION

Sample calculation steel-wood; shear connection

System: Shear connection steel to wood
 Steel: $t_1 = 10 \text{ mm}$; S235
 Wood: $b/h = 120 \text{ mm} / 360 \text{ mm}$, hardwood, ($\rho_k = 680 \text{ kg/m}^3$)
 Calculation base: Measurement: EC5 or DIN EN 1995-1-1:2010-12 and national German application document DIN 20000-6:2012-06; ETA 11/0190 ASSY wood screws.
 Anchor force: $F_{Ed} = 640 \text{ kN}$ (NKL = 1, KLED = „mean“)
 Prerequisite: Exact fit for the screw head in the steel plate

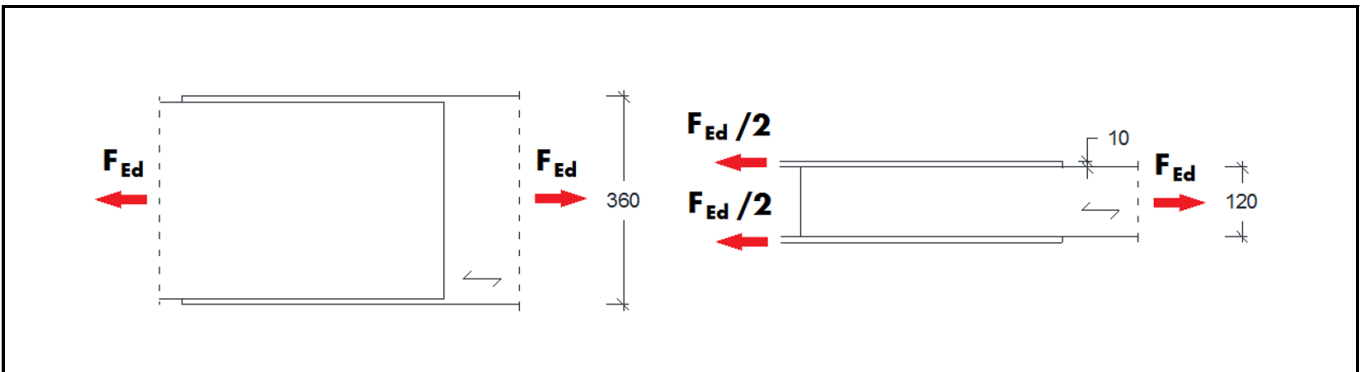

Alternative - ASSY 3.0 Combi: Shear capacity hardwood/Beechwood laminated veneer lumber steel-wood $\alpha_2 = 90^\circ$ - ASSY 3.0 Combi
 Lumber thickness: $t_2 = 120 \text{ mm}$

SHEAR CAPACITY HARDWOOD/BEECHWOOD LAMINATED VENEER LUMBER STEEL-WOOD $\alpha_2 = 90^\circ$ ASSY 3.0 KOMBI

ASSY 3.0 Combi - Shear capacity $F_{v,Rk}$ and $F_{v,Rd}$ ($k_{mod} = 0.8$) with required minimum screw length l_{min}

t_2 mm	Ø 8mm $t_s = 8 \text{ mm}$		Ø 10mm $t_s = 10 \text{ mm}$		Ø 12mm $t_s = 12 \text{ mm}$	
	$F_{v,Rk}$ kN	l_{min} mm	$F_{v,Rk}$ kN	l_{min} mm	$F_{v,Rk}$ kN	l_{min} mm
80	8,26	80	11,67	80		
	5,08	80	7,18	80		
100	8,59	100	12,05	100	16,17	100
	5,29	100	7,42	100	9,95	100
120	9,26	120	12,81	120	17,09	120
	5,70	120	7,88	120	10,51	120
...	9,26	120	13,57	140	17,09	120

Selected: ASSY 3.0 Combi 10 x 120 mm

$F_{v,Rd} = 7,88 \text{ kN}$ (NKL = 1, KLED = „mean“)

NOTE: These represent planning aids. The values are to be measured by authorized persons for a specific project.

USES FOR HARDWOOD/BEECHWOOD LAMINATED VENEER LUMBER/STEEL-WOOD SHEAR CONNECTION

The arrangement of the screws is selected such that it is not required to reduce the effective number of screws ($n_{ef} = n$). Screws placed in a row in the direction of the grain are organised offset by the screw diameter $d = 10$ mm at a right angle to the direction of the grain.

Required number of screws per sheet for $n_{ef} = n$:

$$\text{erf. } n = 0,5 \times F_{Ed} / F_{v,Rd} = 0,5 \times 640 \text{ kN} / 7,88 \text{ kN} = 41$$

Minimum spacing per ETA-11/0190 A.1.4.2:

$$a_1 \geq 0,7 \times (4 + |\cos 0^\circ|) \times 10 = 35 \text{ mm}$$

$$a_2 \geq 0,7 \times (3 + |\sin 0^\circ|) \times 10 = 21 \text{ mm}$$

$$a_{3,i} \geq (7 + 5 \times \cos 0^\circ) \times 10 = 120 \text{ mm}$$

$$a_{4,c} \geq 3 \times 10 = 30 \text{ mm}$$

Maximum number of screws at a right angle to the direction of the grain:

$$n_{90} = (h - 2 \times a_{4,c} + d) / a_2 + 1 = (360 - 2 \times 30 + 10) / 21 + 1 = 14$$

Number of screws in the direction of the grain in a row:

$$n_0 = \text{erf. } n / n_{90} = 41 / 14 = 3$$

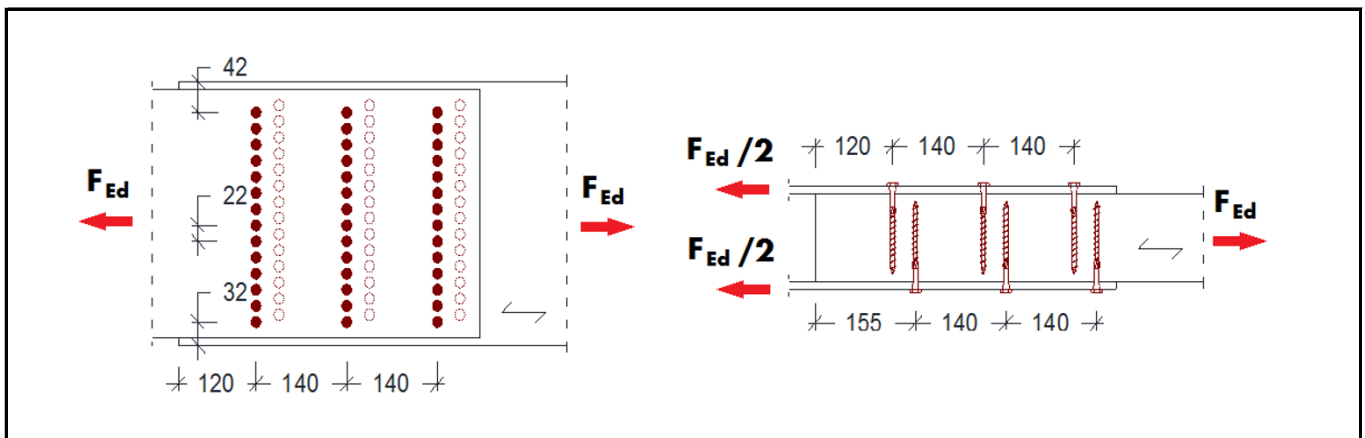

Verification of load capacity:

$$\frac{F_{v,Ed}}{n_{v,ef} \cdot F_{v,Rd}} = \frac{640}{2 \cdot 3 \cdot 14 \cdot 7,88} = 0,97 \leq 1$$

Additional verification:

Tension load capacity for wood based on net cross section, tensile load capacity of the steel sheet, embedment strength of the steel sheet

NOTE: These represent planning aids. The values are to be measured by authorized persons for a specific project.

USE FOR HARDWOOD/BEECHWOOD LAMINATED VENEER LUMBER/STEEL-WOOD SHEAR CONNECTION

Sample calculation steel-wood; shear connection:

System: Shear connection (45°) steel to wood
 Steel: $t_1 = 6 \text{ mm}$; S235
 Wood: $b/h = 120 \text{ mm} / 360 \text{ mm}$, hardwood, ($\rho_k = 680 \text{ kg/m}^3$)
 Calculation base: Measurement: EC5 or DIN EN 1995-1-1:2010-12 and national German application document DIN 20000-6:2012-06; ETA 11/0190 ASSY wood screws.
 Anchor force: $F_{Ed} = 640 \text{ kN}$ (NKL = 1, KLED = „mean“)
 Objective: Minimisation of the required number of screws

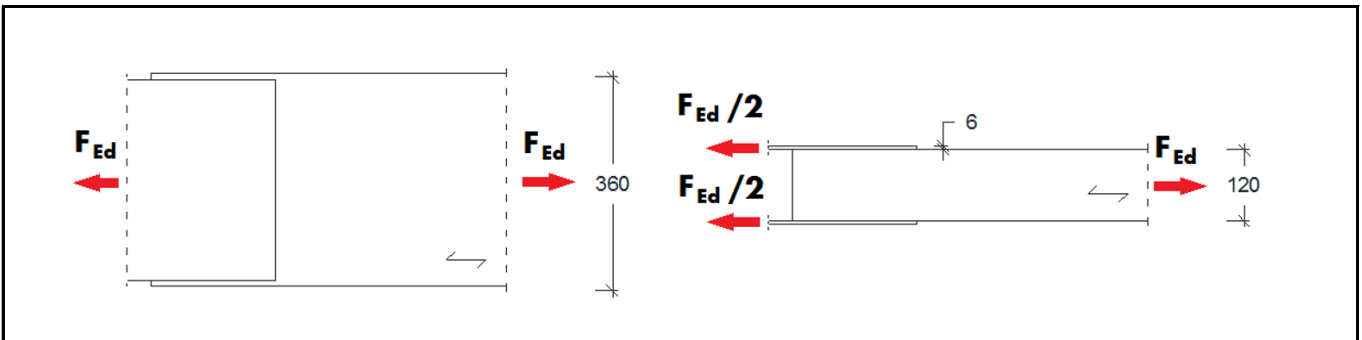

Alternative - ASSY plus VG:

Lap shear hardwood/Beechwood laminated veneer lumber steel-wood $\alpha_2 = 45^\circ$ - ASSY plus VG countersunk head with angle plate
 Lumber thickness: $t_2 = 120 \text{ mm}$

**LAP SHEAR HARDWOOD/BEECHWOOD LAMINATED VENEER LUMBER STEEL-WOOD $\alpha_2 = 45^\circ$
 ASSY PLUS VG COUNTERSUNK + ANGLE PLATE**

ASSY plus VG - Lap shear capacity $F_{v,Rk}$ and $F_{v,Rd}$ ($k_{mod} = 0,8$ and $\gamma_M = 1,3$) with required $l_{a,min}$ minimum screw length $l_{a,min}$

t_2 mm	∅ 6mm		∅ 8mm		∅ 10mm		∅ 12mm	
	$t_{s,min} = 3\text{mm}$		$t_{s,min} = 4\text{mm}$		$t_{s,min} = 5\text{mm}$		$t_{s,min} = 6\text{mm}$	
	$F_{v,Rk}$ kN	$l_{a,min}$ mm	$F_{v,Rk}$ kN	$l_{a,min}$ mm	$F_{v,Rk}$ kN	$l_{a,min}$ mm	$F_{v,Rk}$ kN	$l_{a,min}$ mm
60	4,18	80						
80	7,14	120	8,13	120	7,87	120	8,36	120
	4,39	120	5,01	120	4,84	120	5,14	120
100	7,78	140	10,0	140	10,0	140	13,5	160
	5,31	140	6,17	140	6,17	140	8,31	160
120	7,78	140	13,8	180	14,3	180	16,1	180
	5,98	160	8,49	180	8,81	180	9,90	180
	17,78	1140	114,1	1200	16,5	1200	18,7	1200

$F_{v,Rk}$ kN	$l_{a,min}$ mm
$F_{v,Rk}$	
$F_{v,Rd}$	

Selected:

ASSY plus VG countersunk head 8 x 180 mm + angle plate 45°

$F_{v,Rd} = 8,49 \text{ kN}$ (NKL = 1, KLED = „mean“)

NOTE: These represent planning aids. The values are to be measured by authorized persons for a specific project.

USE FOR HARDWOOD/BEECHWOOD LAMINATED VENEER LUMBER/STEEL-WOOD SHEAR CONNECTION

Friction between the steel and wood components may be estimated if pressure on the steel sheets in contact with the wood components is not impeded. ($\mu = 0.25$)

Required number of screws per sheet for $n_{ef} = n$:

$$\text{erf. } n = F_{Ed} / (2 \times (1 + \mu) \times F_{v,Rd}) = 640 / (2 \times 1,25 \times 8,49) = 30,2$$

Minimum spacing per ETA-11/0190 A.1.4.2:

$$\alpha_1 \geq 5 \times d = 40 \text{ mm} \quad \text{selected } 70 \text{ mm}$$

$$\alpha_2 \geq 2,5 \times d = 20 \text{ mm} \quad \text{selected } 26 \text{ mm}$$

$$\alpha_1 \times \alpha_2 \geq 25 \times d^2$$

$$\alpha_{1,c} \geq 5 \times d = 40 \text{ mm}$$

$$\alpha_{2,c} \geq 3 \times d = 24 \text{ mm} \quad \text{selected } 31 \text{ mm}$$

Maximum number of screws at a right angle to the direction of the grain:

$$h_{90} = 1 + (h - 2 \times \alpha_{2,c} - 1,5 \times d) / \alpha_2 = 1 + (360 - 2 \times 31 - 1,5 \times 8) / 26 = 12$$

Number of screws in the direction of the grain in a row:

$$\text{erf. } n_0 = \text{erf. } n / n_{90} = 30,2 / 12 = 2,52$$

$$n_0 = 3$$

$$n_{0,ef} = \max\{n_0^{0,9}; 0,9 \times n_0\} = \max\{3^{0,9}; 0,9 \times 3\} = 2,7$$

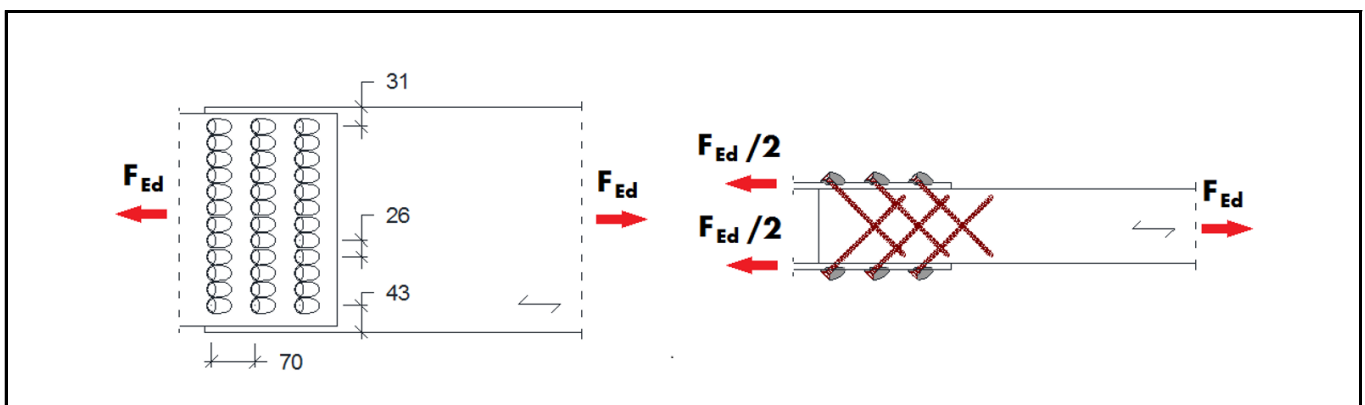

Verification of load capacity:

$$\frac{F_{v,Ed}}{n_{ef} \cdot F_{v,Rd}} = \frac{640}{2 \cdot 12 \cdot 2,7 \cdot 1,25 \cdot 8,49} = 0,93 \leq 1$$

Additional verification:

Tension load capacity for wood based on net cross section, tensile load capacity of the steel sheet, embedment strength of the steel sheet.

NOTE: These represent planning aids. The values are to be measured by authorized persons for a specific project.

KEY TABLES HARDWOOD/BEECHWOOD LAMINATED VENEER LUMBER/STEEL-WOOD CONNECTIONS

Key

$F_{ax,Rk}$ Characteristic load capacity in [kN] for a screw when being withdrawn at an angle between the veneer layers and screw axis of 0° or 90° .

$F_{ax,Rd}$ Pull: Rated value for load capacity in [kN] for a screw when being withdrawn for an angle between the veneer layers and screw axis of 0° or 90° with $k_{mod} = 0,8$ and $\gamma_M = 1,3$ dependent upon the thread reach.

$F_{v,Rk}$ Characteristic load capacity in [kN] for a screw for shearing at an angle between the veneer layers and screw axis of 0° or 90° . In the case of tensile shear strength, the angle between the screw axis and the shear force is 45° .

$F_{v,Rd}$ Rated value for load capacity in [kN] for a screw for shearing at an angle between the veneer layers and screw axis of 0° or 90° with $k_{mod} = 0,8$ and $\gamma_M = 1,3$. In the case of tensile shear strength, the angle between the screw axis and the shear force is 45° .

α_i Angle between screw axis and grain / ply direction of the component's veneers

l Screw length in [mm]

l_{min} Minimum screw length with which the indicated load capacity is achieved in [mm]

l_{ef} Effective anchorage length of the threads in [cm]

d Nominal diameter/Thread outer diameter for screws in [mm]

t_1 Thickness of the steel component

t_s Thickness of the steel component (minimum and maximum)

t_2 Side lumber thickness on the screw tip side component 2 at $\alpha = 0^\circ$ or 90° in [mm]: $t_2 \geq l_{min} - t_1$

Side lumber thickness on the screw tip side component 2 (shear application) $\alpha = 45^\circ$ in [mm]; component 2: $t_2 \geq l_{min} / 1,414 - t_1$

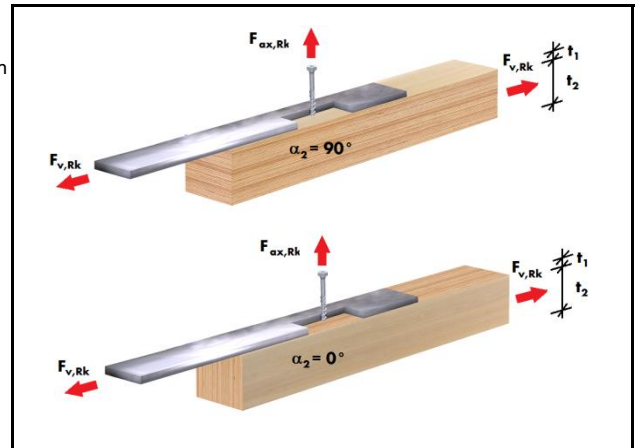

Explanatory notes to the tables

Ø 6mm		
$t_{s,min} = 3mm$		
$t_{s,max} = 6mm$		
$F_{v,R}$	l_{min}	
kN	mm	
Characteristic value $F_{v,Rk}$ and/or $F_{ax,Rk}$	7,78 140	l_{min} for $F_{v,Rk}$ and/or F_{ax}
Rated value ($k_{mod} = 0,8$) $F_{v,Rd}$ and/or $F_{ax,Rd}$	5,98 160	l_{min} for $F_{v,Rd}$ and/or F_{ax}

Note when using angle plates: The load capacity and minimum screw lengths apply for the maximum sheet thickness. Increase wood thickness may be necessary in the case of reduced sheet thickness.

NOTE: These represent planning aids. The values are to be measured by authorized persons for a specific project.

KEY TABLES HARDWOOD/BEECHWOOD LAMINATED VENEER LUMBER/STEEL-WOOD CONNECTIONS

General information

- Single shear steel-wood connection with or without angle plate and screws in pre-drilled holes. Calculated values apply to Beechwood laminated veneer lumber that conforms to product-specific AbZ Z-9.1-837. All screws must be installed flush.
- Pre-drilled hole diameter per ETA-11/0190

Thread outer diameter in mm	5	6	7	8	10	12	14
Pre-drill diameter in mm	3,5	4	5	6	7	8	9

- Screws made of carbon steel may only be used in use categories 1 and 2. (exception: hot-dip galvanized ASSY plus VG Ø14)
- Individual load capacity for a screw with a characteristic density of $\rho_k \geq 680 \text{ kg/m}^3$. The characteristic density was limited to $\rho_k \geq 590 \text{ kg/m}^3$ for axial loads. In the case of connections using multiple screws, the effective number of screws n_{ef} per DIN EN 1995-1-1 (8.17) and/or ETA-11/0190 A.1.3.1 must be adhered to.
- Load-bearing connections must comprise at least two screws. Deviations from this are possible per DIN EN 1995-1-1/NA:2010-12, NCI to 8.3.1.2 (NA.10) and ETA-11/0190, 4.2.
- Shear application: The value for shear capacity F_v can be multiplied by 1.25 if friction between the two components is taken into account.

Calculation bases

DIN EN 1995-1-1:2010-12	Measurement and design of wooden structures - General rules and rules for wooden construction
DIN EN 1995-1-1/NA:2013-08	National application - Nationally-defined parameters
DIN 20000-6	Use of construction products in structures Part 6: Dowel type and non-dowel type fasteners
ETA-11/0190	Würth self-tapping screws for use in timber constructions
AbZ Z-9.1-837	Laminated timber from beechwood - veneer laminates

NOTE: These represent planning aids. The values are to be measured by authorized persons for a specific project.

SHEAR CAPACITY HARDWOOD/BEECHWOOD LAMINATED VENEER LUMBER/STEEL-WOOD

$\alpha_2 = 90^\circ$ ASSY 3.0 + ASSY 3.0 ZINI

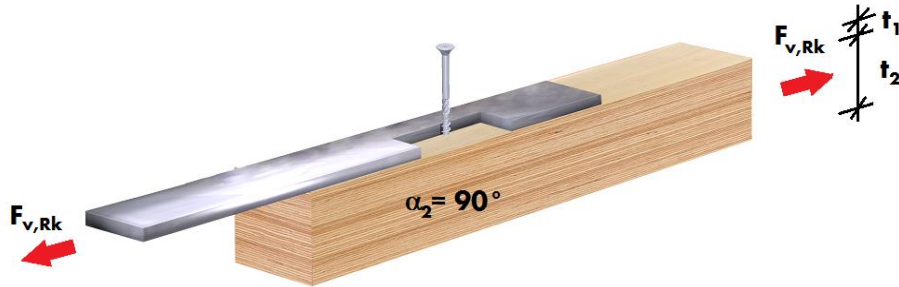

ASSY 3.0 - Shear capacity $F_{v,Rk}$ and $F_{v,Rd}$ ($k_{mod} = 0,8$) with required minimum screw length l_{min}

t_2 mm	Ø 5mm $t_s = 5mm$		Ø 6mm $t_s = 6mm$		Ø 7mm $t_s = 7mm$		Ø 8mm $t_s = 8mm$		Ø 10mm $t_s = 10mm$	
	$F_{v,R}$ kN	l_{min} mm	$F_{v,R}$ kN	l_{min} mm	$F_{v,R}$ kN	l_{min} mm	$F_{v,R}$ kN	l_{min} mm	$F_{v,R}$ kN	l_{min} mm
40	3,56	45	4,60	40						
	2,19	45	2,83	40						
50	3,60	55	4,81	50						
	2,22	55	2,96	50						
60	3,72	60	4,94	60						
	2,29	60	3,04	60						
80	3,83	70	5,29	80	6,71	80	8,26	80	11,67	80
	2,36	70	3,25	80	4,13	80	5,08	80	7,18	80
100	4,06	100	5,55	100	7,02	100	8,59	100	12,05	100
	2,50	100	3,41	100	4,32	100	5,29	100	7,42	100
120	4,29	120	5,81	110	7,32	120	9,26	120	12,81	120
	2,64	120	3,57	110	4,51	120	5,70	120	7,88	120
140	4,29	120	5,81	110	7,32	120	9,26	120	12,81	120
	2,64	120	3,57	110	4,51	120	5,70	120	7,88	120
160	4,29	120	5,81	110	7,78	160	9,26	120	13,57	160
	2,64	120	3,57	110	4,79	160	5,70	120	8,35	160
180	4,29	120	5,81	110	7,78	160	9,26	120	13,57	160
	2,64	120	3,57	110	4,79	160	5,70	120	8,35	160
200	4,29	120	5,81	110	7,78	160	9,26	120	13,57	160
	2,64	120	3,57	110	4,79	160	5,70	120	8,35	160
220	4,29	120	5,81	110	7,78	160	9,93	220	13,57	160
	2,64	120	3,57	110	4,79	160	6,11	220	8,35	160
240	4,29	120	5,81	110	7,78	160	9,93	220	13,57	160
	2,64	120	3,57	110	4,79	160	6,11	220	8,35	160
260	4,29	120	5,81	110	7,78	160	9,93	220	13,57	160
	2,64	120	3,57	110	4,79	160	6,11	220	8,35	160
280	4,29	120	5,81	110	7,78	160	9,93	220	13,57	160
	2,64	120	3,57	110	4,79	160	6,11	220	8,35	160
300	4,29	120	5,81	110	7,78	160	9,93	220	13,57	160
	2,64	120	3,57	110	4,79	160	6,11	220	8,35	160
320	4,29	120	5,81	110	7,78	160	9,93	220	14,33	320
	2,64	120	3,57	110	4,79	160	6,11	220	8,82	320
340	4,29	120	5,81	110	7,78	160	9,93	220	14,33	320
	2,64	120	3,57	110	4,79	160	6,11	220	8,82	320
360	4,29	120	5,81	110	7,78	160	9,93	220	14,33	320
	2,64	120	3,57	110	4,79	160	6,11	220	8,82	320

$F_{v,R}$ kN	l_{min} mm
	$F_{v,Rk}$
	$F_{v,Rd}$

General information

ASSY screws are to be pre-drilled for hardwood or Beechwood laminated veneer lumber per ETA-11/0190 Table 1.

Ø	Pre-drilling Ø
5 mm	3.5 mm
6 mm	4 mm
7 mm	5 mm
8 mm	6 mm
10 mm	7 mm
12 mm	8 mm
14 mm	9 mm

Calculation base

- ETA-11/0190
- EN 1995-1-1:2010-12

The exceptions listed in key chapter must be taken into consideration.

NOTE: These represent planning aids. The values are to be measured by authorized persons for a specific project.

SHEAR CAPACITY HARDWOOD/BEECHWOOD LAMINATED VENEER LUMBER/STEEL-WOOD

$\alpha_2 = 90^\circ$ ASSY 3.0 COMBI

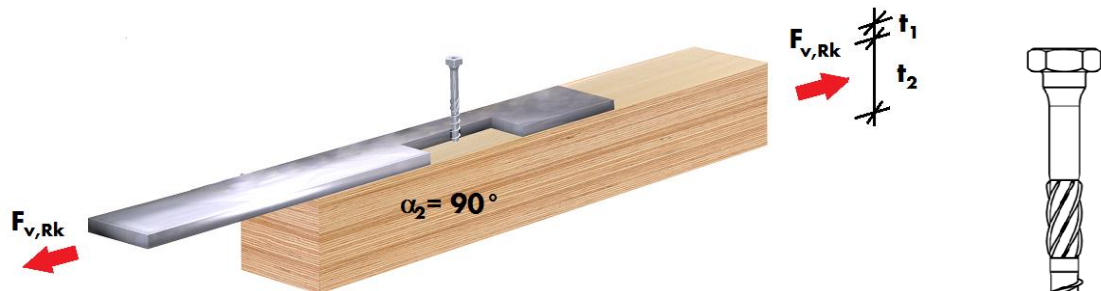

ASSY 3.0 Combi - Shear capacity $F_{v,Rk}$ and $F_{v,Rd}$ ($k_{mod} = 0,8$) with required minimum screw length l_{min}

t_2 mm	\varnothing 8mm $t_s = 8$ mm		\varnothing 10mm $t_s = 10$ mm		\varnothing 12mm $t_s = 12$ mm	
	$F_{v,R}$ kN	l_{min} mm	$F_{v,R}$ kN	l_{min} mm	$F_{v,R}$ kN	l_{min} mm
80	8,26	80	11,67	80		
	5,08	80	7,18	80		
100	8,59	100	12,05	100	16,17	100
	5,29	100	7,42	100	9,95	100
120	9,26	120	12,81	120	17,09	120
	5,70	120	7,88	120	10,51	120
140	9,26	120	13,57	140	17,09	120
	5,70	120	8,35	140	10,51	120
160	9,26	120	13,57	140	18,00	160
	5,70	120	8,35	140	11,07	160
180	9,26	120	13,57	140	18,00	160
	5,70	120	8,35	140	11,07	160
200	9,26	120	13,57	140	18,00	160
	5,70	120	8,35	140	11,07	160
220	9,93	220	13,57	140	18,91	220
	6,11	220	8,35	140	11,64	220
240	9,93	220	13,57	140	18,91	220
	6,11	220	8,35	140	11,64	220
260	9,93	220	13,57	140	18,91	220
	6,11	220	8,35	140	11,64	220
280	9,93	220	13,57	140	18,91	220
	6,11	220	8,35	140	11,64	220
300	9,93	220	13,57	140	18,91	220
	6,11	220	8,35	140	11,64	220
320	9,93	220	14,33	320	18,91	220
	6,11	220	8,82	320	11,64	220
340	9,93	220	14,33	320	18,91	220
	6,11	220	8,82	320	11,64	220
360	9,93	220	14,33	320	18,91	220
	6,11	220	8,82	320	11,64	220
380	9,93	220	14,33	320	20,05	380
	6,11	220	8,82	320	12,34	380
400	9,93	220	14,33	320	20,05	380
	6,11	220	8,82	320	12,34	380
420	9,93	220	14,33	320	20,05	380
	6,11	220	8,82	320	12,34	380

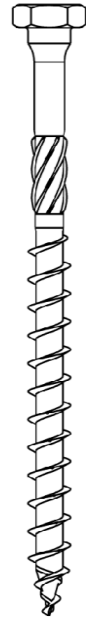

$F_{v,R}$ kN	l_{min} mm
	$F_{v,Rk}$
	$F_{v,Rd}$

General information

ASSY screws are to be pre-drilled for hardwood or Beechwood laminated veneer lumber per ETA-11/0190 Table 1.

\varnothing	Pre-drilling \varnothing
5 mm	3.5 mm
6 mm	4 mm
7 mm	5 mm
8 mm	6 mm
10 mm	7 mm
12 mm	8 mm
14 mm	9 mm

Calculation base

- ETA-11/0190
- EN 1995-1-1:2010-12

The exceptions listed in key chapter must be taken into consideration.

NOTE: These represent planning aids. The values are to be measured by authorized persons for a specific project.

SHEAR CAPACITY HARDWOOD/BEECHWOOD LAMINATED VENEER LUMBER/STEEL-WOOD

$\alpha_2 = 90^\circ$ ASSY PLUS VG COUNTERSUNK

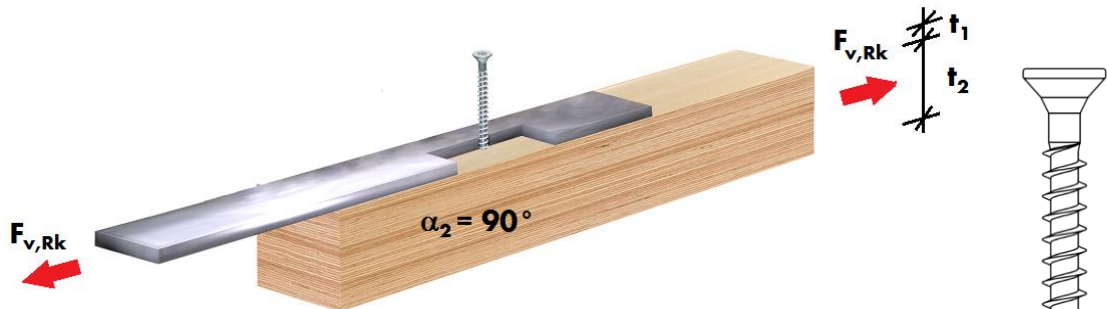

ASSY plus VG - Shear capacity $F_{v,Rk}$ and $F_{v,Rd}$ ($k_{mod} = 0,8$) with required minimum screw length l_{min}

t_2 mm	Ø 6mm		Ø 8mm		Ø 10mm		Ø 12mm	
	$t_s = 6mm$		$t_s = 8mm$		$t_s = 10mm$		$t_s = 12mm$	
	$F_{v,R}$ kN	l_{min} mm	$F_{v,R}$ kN	l_{min} mm	$F_{v,R}$ kN	l_{min} mm	$F_{v,R}$ kN	l_{min} mm
80	5,73	80						
	3,53	80						
100	6,25	100						
	3,85	100						
120	6,73	120	9,96	120	13,46	120	17,72	120
	4,14	120	6,13	120	8,28	120	10,91	120
140	6,73	120	10,6	140	14,22	140	18,63	140
	4,14	120	6,54	140	8,75	140	11,47	140
160	6,73	120	11,3	160	14,98	160	19,55	160
	4,14	120	6,95	160	9,22	160	12,03	160
180	6,73	120	11,6	180	15,74	180	20,46	180
	4,14	120	7,13	180	9,68	180	12,59	180
200	6,73	120	11,6	180	16,50	200	21,37	200
	4,14	120	7,13	180	10,15	200	13,15	200
220	6,73	120	11,6	180	17,25	220	22,28	220
	4,14	120	7,13	180	10,62	220	13,71	220
240	6,73	120	11,6	180	18,01	240	23,19	240
	4,14	120	7,13	180	11,09	240	14,27	240
260	6,73	120	11,6	180	18,77	260	23,42	260
	4,14	120	7,13	180	11,55	260	14,41	260
280	6,73	120	11,6	180	19,53	280	24,33	280
	4,14	120	7,13	180	12,02	280	14,97	280
300	6,73	120	11,6	180	19,55	300	24,69	300
	4,14	120	7,13	180	12,03	300	15,19	300
320	6,73	120	11,6	180	19,55	300	24,69	300
	4,14	120	7,13	180	12,03	300	15,19	300
340	6,73	120	11,6	180	19,55	300	24,69	300
	4,14	120	7,13	180	12,03	300	15,19	300
360	6,73	120	11,6	180	19,55	300	24,69	300
	4,14	120	7,13	180	12,03	300	15,19	300
380	6,73	120	11,6	180	19,55	300	24,69	300
	4,14	120	7,13	180	12,03	300	15,19	300

$F_{v,R}$ kN	l_{min} mm
	$F_{v,Rk}$
	$F_{v,Rd}$

General information

ASSY screws are to be pre-drilled for hardwood or Beechwood laminated veneer lumber per ETA-11/0190 Table 1.

Ø	Pre-drilling Ø
5 mm	3.5 mm
6 mm	4 mm
7 mm	5 mm
8 mm	6 mm
10 mm	7 mm
12 mm	8 mm
14 mm	9 mm

Calculation base

- ETA-11/0190
- EN 1995-1-1:2010-12

The exceptions listed in key chapter must be taken into consideration.

NOTE: These represent planning aids. The values are to be measured by authorized persons for a specific project.

SHEAR CAPACITY HARDWOOD/BEECHWOOD LAMINATED VENEER LUMBER/STEEL-WOOD

$\alpha_2 = 0^\circ$ ASSY 3.0 + ASSY 3.0 ZINI

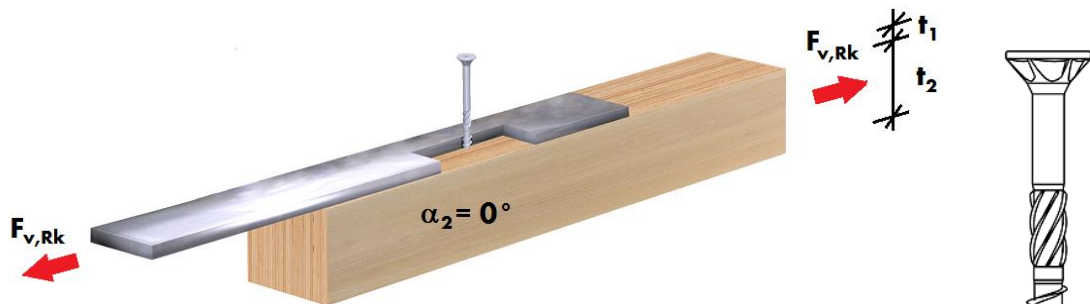

ASSY 3.0 - Shear capacity $F_{v,Rk}$ and $F_{v,Rd}$ ($k_{mod} = 0,8$) with required minimum screw length l_{min}

t_2 mm	$\varnothing 5\text{mm}$ $t_s = 5\text{mm}$		$\varnothing 6\text{mm}$ $t_s = 6\text{mm}$		$\varnothing 7\text{mm}$ $t_s = 7\text{mm}$		$\varnothing 8\text{mm}$ $t_s = 8\text{mm}$		$\varnothing 10\text{mm}$ $t_s = 10\text{mm}$	
	$F_{v,R}$ kN	l_{min} mm	$F_{v,R}$ kN	l_{min} mm	$F_{v,R}$ kN	l_{min} mm	$F_{v,R}$ kN	l_{min} mm	$F_{v,R}$ kN	l_{min} mm
80	2,11	80								
	1,30	80								
100	2,17	100	2,99	100						
	1,34	100	1,84	100						
120	2,24	120	3,06	110	3,92	120	4,97	120		
	1,38	120	1,89	110	2,41	120	3,06	120		
140	2,24	120	3,06	110	3,92	120	4,97	120		
	1,38	120	1,89	110	2,41	120	3,06	120		
160	2,24	120	3,06	110	4,06	160	4,97	120	7,32	160
	1,38	120	1,89	110	2,50	160	3,06	120	4,51	160
180	2,24	120	3,06	110	4,06	160	4,97	120	7,32	160
	1,38	120	1,89	110	2,50	160	3,06	120	4,51	160
200	2,24	120	3,06	110	4,06	160	4,97	120	7,32	160
	1,38	120	1,89	110	2,50	160	3,06	120	4,51	160
220	2,24	120	3,06	110	4,06	160	5,17	220	7,32	160
	1,38	120	1,89	110	2,50	160	3,18	220	4,51	160
240	2,24	120	3,06	110	4,06	160	5,17	220	7,32	160
	1,38	120	1,89	110	2,50	160	3,18	220	4,51	160
260	2,24	120	3,06	110	4,06	160	5,17	220	7,32	160
	1,38	120	1,89	110	2,50	160	3,18	220	4,51	160
280	2,24	120	3,06	110	4,06	160	5,17	220	7,32	160
	1,38	120	1,89	110	2,50	160	3,18	220	4,51	160
300	2,24	120	3,06	110	4,06	160	5,17	220	7,32	160
	1,38	120	1,89	110	2,50	160	3,18	220	4,51	160
320	2,24	120	3,06	110	4,06	160	5,17	220	7,55	320
	1,38	120	1,89	110	2,50	160	3,18	220	4,65	320
340	2,24	120	3,06	110	4,06	160	5,17	220	7,55	320
	1,38	120	1,89	110	2,50	160	3,18	220	4,65	320
360	2,24	120	3,06	110	4,06	160	5,17	220	7,55	320
	1,38	120	1,89	110	2,50	160	3,18	220	4,65	320
380	2,24	120	3,06	110	4,06	160	5,17	220	7,55	320
	1,38	120	1,89	110	2,50	160	3,18	220	4,65	320
400	2,24	120	3,06	110	4,06	160	5,17	220	7,55	320
	1,38	120	1,89	110	2,50	160	3,18	220	4,65	320
420	2,24	120	3,06	110	4,06	160	5,17	220	7,55	320
	1,38	120	1,89	110	2,50	160	3,18	220	4,65	320

$F_{v,R}$ kN	l_{min} mm
	$F_{v,Rk}$
	$F_{v,Rd}$

General information

ASSY screws are to be pre-drilled for hardwood or Beechwood laminated veneer lumber per ETA-11/0190 Table 1.

\varnothing	Pre-drilling \varnothing
5 mm	3.5 mm
6 mm	4 mm
7 mm	5 mm
8 mm	6 mm
10 mm	7 mm
12 mm	8 mm
14 mm	9 mm

Calculation base

- ETA-11/0190
- EN 1995-1-1:2010-12

The exceptions listed in key chapter must be taken into consideration.

NOTE: These represent planning aids. The values are to be measured by authorized persons for a specific project.

SHEAR CAPACITY HARDWOOD/BEECHWOOD LAMINATED VENEER LUMBER/STEEL-WOOD

$\alpha_2 = 0^\circ$ ASSY 3.0 COMBI

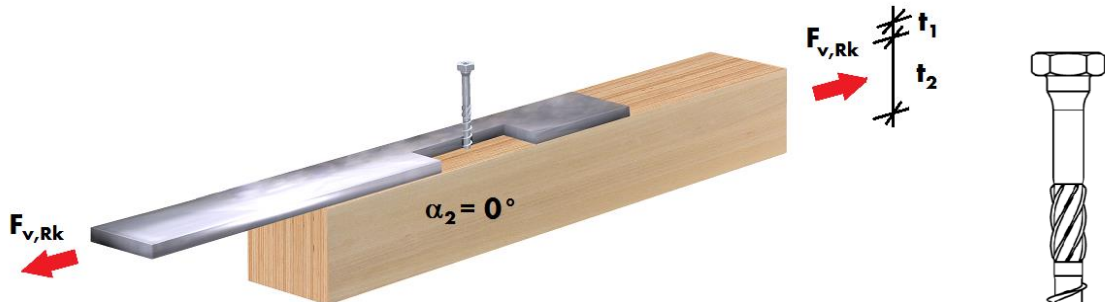

ASSY 3.0 Combi - Shear capacity $F_{v,Rk}$ and $F_{v,Rd}$ ($k_{mod} = 0,8$) with required minimum screw length l_{min}

t_2 mm	\varnothing 8mm $t_s = 8$ mm		\varnothing 10mm $t_s = 10$ mm		\varnothing 12mm $t_s = 12$ mm	
	$F_{v,R}$ kN	l_{min} mm	$F_{v,R}$ kN	l_{min} mm	$F_{v,R}$ kN	l_{min} mm
80						
100						
120	4,97	120				
	3,06	120				
140	4,97	120				
	3,06	120				
160	4,97	120	7,32	160		
	3,06	120	4,51	160		
180	4,97	120	7,32	160	9,87	180
	3,06	120	4,51	160	6,07	180
200	4,97	120	7,32	160	9,87	180
	3,06	120	4,51	160	6,07	180
220	5,17	220	7,32	160	10,1	220
	3,18	220	4,51	160	6,24	220
240	5,17	220	7,32	160	10,1	220
	3,18	220	4,51	160	6,24	220
260	5,17	220	7,32	160	10,1	220
	3,18	220	4,51	160	6,24	220
280	5,17	220	7,32	160	10,1	220
	3,18	220	4,51	160	6,24	220
300	5,17	220	7,32	160	10,1	220
	3,18	220	4,51	160	6,24	220
320	5,17	220	7,55	320	10,1	220
	3,18	220	4,65	320	6,24	220
340	5,17	220	7,55	320	10,1	220
	3,18	220	4,65	320	6,24	220
360	5,17	220	7,55	320	10,1	220
	3,18	220	4,65	320	6,24	220
380	5,17	220	7,55	320	10,5	380
	3,18	220	4,65	320	6,45	380
400	5,17	220	7,55	320	10,5	380
	3,18	220	4,65	320	6,45	380
420	5,17	220	7,55	320	10,5	380
	3,18	220	4,65	320	6,45	380

$F_{v,R}$ kN	l_{min} mm
	$F_{v,Rk}$
	$F_{v,Rd}$

General information

ASSY screws are to be pre-drilled for hardwood or Beechwood laminated veneer lumber per ETA-11/0190 Table 1.

\varnothing	Pre-drilling \varnothing
5 mm	3.5 mm
6 mm	4 mm
7 mm	5 mm
8 mm	6 mm
10 mm	7 mm
12 mm	8 mm
14 mm	9 mm

Calculation base

- ETA-11/0190
- EN 1995-1-1:2010-12

The exceptions listed in key chapter must be taken into consideration.

NOTE: These represent planning aids. The values are to be measured by authorized persons for a specific project.

SHEAR CAPACITY HARDWOOD/BEECHWOOD LAMINATED VENEER LUMBER/STEEL-WOOD

$\alpha_2 = 0^\circ$ ASSY PLUS VG COUNTERSUNK

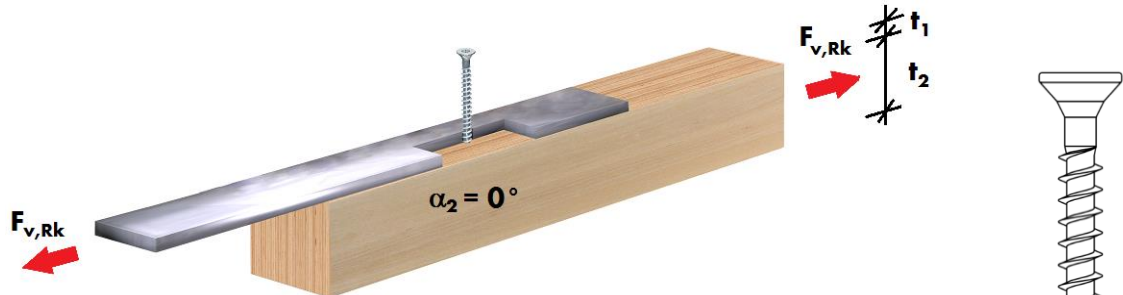

ASSY plus VG - Shear capacity $F_{v,Rk}$ and $F_{v,Rd}$ ($k_{mod} = 0,8$) with required minimum screw length l_{min}

t_2 mm	\varnothing 6mm		\varnothing 8mm		\varnothing 10mm		\varnothing 12mm	
	$t_s = 6mm$		$t_s = 8mm$		$t_s = 10mm$		$t_s = 12mm$	
	$F_{v,R}$ kN	l_{min} mm	$F_{v,R}$ kN	l_{min} mm	$F_{v,R}$ kN	l_{min} mm	$F_{v,R}$ kN	l_{min} mm
120	3,36	120	5,18	120				
	2,06	120	3,19	120				
160	3,64	160	5,58	160	7,74	160		
	2,24	160	3,43	160	4,77	160		
200	3,95	200	5,98	200	8,20	200	10,9	200
	2,43	200	3,68	200	5,05	200	6,69	200
250	4,27	240	6,38	240	8,88	260	11,5	260
	2,63	240	3,93	240	5,47	260	7,07	260
300	4,42	260	6,92	300	9,28	300	12,0	300
	2,72	260	4,26	300	5,71	300	7,41	300
350	4,42	260	7,22	330	9,96	360	12,0	300
	2,72	260	4,45	330	6,13	360	7,41	300
400	4,42	260	7,73	380	10,4	400	13,1	380
	2,72	260	4,75	380	6,41	400	8,08	380
450	4,42	260	8,23	430	10,8	430	13,1	380
	2,72	260	5,06	430	6,62	430	8,08	380
500	4,42	260	8,33	480	11,2	480	14,5	480
	2,72	260	5,13	480	6,90	480	8,92	480
550	4,42	260	8,33	480	11,8	530	14,5	480
	2,72	260	5,13	480	7,25	530	8,92	480
600	4,42	260	8,33	480	12,4	600	16,1	600
	2,72	260	5,13	480	7,61	600	9,93	600
650	4,42	260	8,33	480	12,4	600	16,1	600
	2,72	260	5,13	480	7,61	600	9,93	600
700	4,42	260	8,33	480	12,4	600	16,1	600
	2,72	260	5,13	480	7,61	600	9,93	600
750	4,42	260	8,33	480	12,4	600	16,1	600
	2,72	260	5,13	480	7,61	600	9,93	600
800	4,42	260	8,33	480	12,4	600	16,1	600
	2,72	260	5,13	480	7,61	600	9,93	600

$F_{v,R}$ kN	l_{min} mm
	$F_{v,Rk}$
	$F_{v,Rd}$

General information

ASSY screws are to be pre-drilled for hardwood or Beechwood laminated veneer lumber per ETA-11/0190 Table 1.

\varnothing	Pre-drilling \varnothing
5 mm	3.5 mm
6 mm	4 mm
7 mm	5 mm
8 mm	6 mm
10 mm	7 mm
12 mm	8 mm
14 mm	9 mm

Calculation base

- ETA-11/0190
- EN 1995-1-1:2010-12

The exceptions listed in key chapter must be taken into consideration.

NOTE: These represent planning aids. The values are to be measured by authorized persons for a specific project.

WITHDRAWAL CAPACITY HARDWOOD/BEECHWOOD LVL/STEEL-WOOD

$\alpha_2 = 90^\circ$ ASSY 3.0 + ASSY 3.0 ZINI

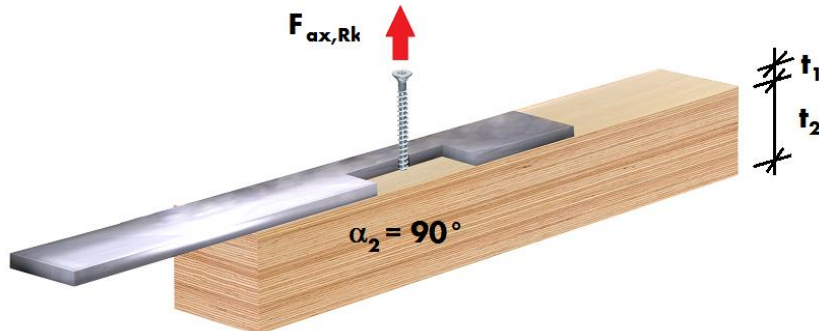

ASSY 3.0 - Withdrawal capacity $F_{ax,Rk}$ and $F_{ax,Rd}$ ($k_{mod} = 0,8$) with required minimum screw length l_{min}

t_2 mm	Ø 5mm $t_s = 5$ mm		Ø 6mm $t_s = 6$ mm		Ø 7mm $t_s = 7$ mm		Ø 8mm $t_s = 8$ mm		Ø 10mm $t_s = 10$ mm	
	$F_{ax,R}$ kN	$F_{ax,R}$ mm	$F_{ax,R}$ kN	l_{min} mm	$F_{ax,R}$ kN	l_{min} mm	$F_{ax,R}$ kN	l_{min} mm	$F_{ax,R}$ kN	l_{min} mm
40	2,73	45	2,51	40						
	1,68	45	1,55	40						
50	2,92	55	3,35	50						
	1,79	55	2,06	50						
60	3,37	60	3,88	60						
	2,07	60	2,39	60						
80	3,83	70	5,24	80	6,11	80	6,68	80	7,59	80
	2,35	70	3,22	80	3,76	80	4,11	80	4,67	80
100	4,74	100	6,29	100	7,33	100	8,02	100	9,11	100
	2,92	100	3,87	100	4,51	100	4,93	100	5,61	100
120	5,65	120	7,33	110	8,56	120	10,7	120	12,15	120
	3,48	120	4,51	110	5,27	120	6,58	120	7,48	120
140	5,65	120	7,33	110	8,56	120	10,7	120	12,15	120
	3,48	120	4,51	110	5,27	120	6,58	120	7,48	120
160	5,65	120	7,33	110	10,4	160	10,7	120	15,19	160
	3,48	120	4,51	110	6,39	160	6,58	120	9,34	160
180	5,65	120	7,33	110	10,4	160	10,7	120	15,19	160
	3,48	120	4,51	110	6,39	160	6,58	120	9,34	160
200	5,65	120	7,33	110	10,4	160	10,7	120	15,19	160
	3,48	120	4,51	110	6,39	160	6,58	120	9,34	160
220	5,65	120	7,33	110	10,4	160	13,4	220	15,19	160
	3,48	120	4,51	110	6,39	160	8,22	220	9,34	160
240	5,65	120	7,33	110	10,4	160	13,4	220	15,19	160
	3,48	120	4,51	110	6,39	160	8,22	220	9,34	160
260	5,65	120	7,33	110	10,4	160	13,4	220	15,19	160
	3,48	120	4,51	110	6,39	160	8,22	220	9,34	160
280	5,65	120	7,33	110	10,4	160	13,4	220	15,19	160
	3,48	120	4,51	110	6,39	160	8,22	220	9,34	160
300	5,65	120	7,33	110	10,4	160	13,4	220	15,19	160
	3,48	120	4,51	110	6,39	160	8,22	220	9,34	160
320	5,65	120	7,33	110	10,4	160	13,4	220	18,22	320
	3,48	120	4,51	110	6,39	160	8,22	220	11,21	320
340	5,65	120	7,33	110	10,4	160	13,4	220	18,22	320
	3,48	120	4,51	110	6,39	160	8,22	220	11,21	320
360	5,65	120	7,33	110	10,4	160	13,4	220	18,22	320
	3,48	120	4,51	110	6,39	160	8,22	220	11,21	320

$F_{ax,R}$ kN	l_{min} mm
	$F_{ax,Rk}$
	$F_{ax,Rd}$

General information

ASSY screws are to be pre-drilled for hardwood or Beechwood laminated veneer lumber per ETA-11/0190 Table 1.

Ø	Pre-drilling Ø
5 mm	3.5 mm
6 mm	4 mm
7 mm	5 mm
8 mm	6 mm
10 mm	7 mm
12 mm	8 mm
14 mm	9 mm

Calculation base

- ETA-11/0190
- EN 1995-1-1:2010-12

The exceptions listed in key chapter must be taken into consideration.

NOTE: These represent planning aids. The values are to be measured by authorized persons for a specific project.

WITHDRAWAL CAPACITY HARDWOOD/BEECHWOOD LVL/STEEL-WOOD

$\alpha_2 = 90^\circ$ ASSY 3.0 COMBI

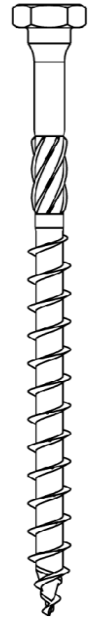
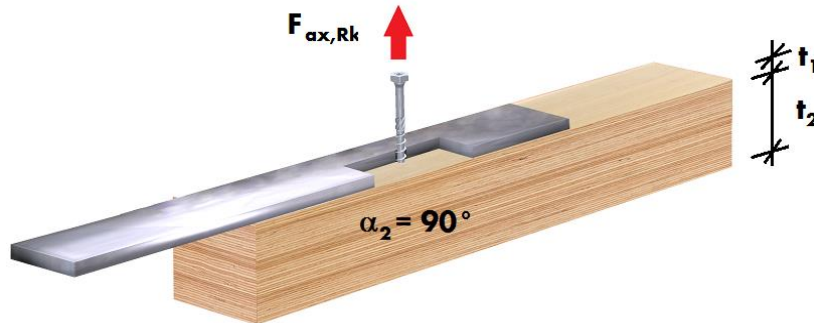

ASSY 3.0 Combi - Withdrawal capacity $F_{ax,Rk}$ and $F_{ax,Rd}$ ($k_{mod} = 0,8$) with required minimum screw length l_{min}

t_2 mm	$\varnothing 8\text{mm}$ $t_s = 8\text{mm}$		$\varnothing 10\text{mm}$ $t_s = 10\text{mm}$		$\varnothing 12\text{mm}$ $t_s = 12\text{mm}$	
	$F_{ax,R}$ kN	l_{min} mm	$F_{ax,R}$ kN	l_{min} mm	$F_{ax,R}$ kN	l_{min} mm
80	6,68	80	7,59	80		
	4,11	80	4,67	80		
100	8,02	100	9,11	100	10,93	100
	4,93	100	5,61	100	6,73	100
120	10,7	120	12,15	120	14,58	120
	6,58	120	7,48	120	8,97	120
140	10,7	120	15,19	140	14,58	120
	6,58	120	9,34	140	8,97	120
160	10,7	120	15,19	140	18,22	160
	6,58	120	9,34	140	11,21	160
180	10,7	120	15,19	140	18,22	160
	6,58	120	9,34	140	11,21	160
200	10,7	120	15,19	140	18,22	160
	6,58	120	9,34	140	11,21	160
220	13,4	220	15,19	140	21,87	220
	8,22	220	9,34	140	13,46	220
240	13,4	220	15,19	140	21,87	220
	8,22	220	9,34	140	13,46	220
260	13,4	220	15,19	140	21,87	220
	8,22	220	9,34	140	13,46	220
280	13,4	220	15,19	140	21,87	220
	8,22	220	9,34	140	13,46	220
300	13,4	220	15,19	140	21,87	220
	8,22	220	9,34	140	13,46	220
320	13,4	220	18,22	320	21,87	220
	8,22	220	11,21	320	13,46	220
340	13,4	220	18,22	320	21,87	220
	8,22	220	11,21	320	13,46	220
360	13,4	220	18,22	320	21,87	220
	8,22	220	11,21	320	13,46	220
380	13,4	220	18,22	320	26,42	380
	8,22	220	11,21	320	16,26	380
400	13,4	220	18,22	320	26,42	380
	8,22	220	11,21	320	16,26	380
420	13,4	220	18,22	320	26,42	380
	8,22	220	11,21	320	16,26	380

$F_{ax,R}$ kN	l_{min} mm
	$F_{ax,Rk}$
	$F_{ax,Rd}$

General information

ASSY screws are to be pre-drilled for hardwood or Beechwood laminated veneer lumber per ETA-11/0190 Table 1.

\varnothing	Pre-drilling \varnothing
5 mm	3.5 mm
6 mm	4 mm
7 mm	5 mm
8 mm	6 mm
10 mm	7 mm
12 mm	8 mm
14 mm	9 mm

Calculation base

- ETA-11/0190
- EN 1995-1-1:2010-12

The exceptions listed in key chapter must be taken into consideration.

NOTE: These represent planning aids. The values are to be measured by authorized persons for a specific project.

WITHDRAWAL CAPACITY HARDWOOD / BEECHWOOD LVL / STEEL-WOOD

$\alpha_2 = 90^\circ$ ASSY PLUS VG COUNTERSUNK

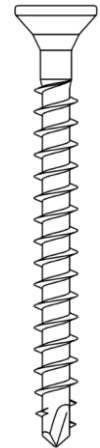
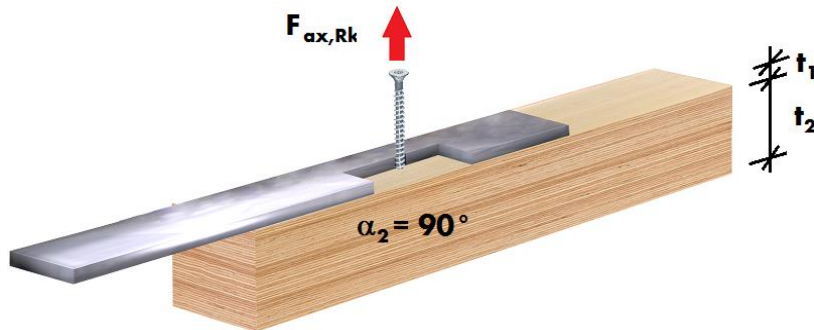

ASSY plus VG - Withdrawal capacity $F_{ax,Rk}$ and $F_{ax,Rd}$ ($k_{mod} = 0,8$) with required minimum screw length l_{min}

t_2 mm	$\varnothing 6\text{mm}$		$\varnothing 8\text{mm}$		$\varnothing 10\text{mm}$		$\varnothing 12\text{mm}$	
	$t_s = 6\text{mm}$		$t_s = 8\text{mm}$		$t_s = 10\text{mm}$		$t_s = 12\text{mm}$	
	$F_{ax,R}$ kN	l_{min} mm	$F_{ax,R}$ kN	l_{min} mm	$F_{ax,R}$ kN	l_{min} mm	$F_{ax,R}$ kN	l_{min} mm
80	7,02	80						
	4,32	80						
100	9,12	100						
	5,61	100						
120	11,0	120	13,5	120	14,7	120	17,1	120
	6,90	120	8,31	120	9,06	120	10,5	120
140	11,0	120	16,2	140	17,8	140	20,8	140
	7,93	140	9,95	140	10,9	140	12,8	140
160	11,0	120	18,8	160	20,8	160	24,4	160
	8,46	160	11,6	160	12,8	160	15,0	160
180	11,0	120	20,0	180	23,8	180	28,1	180
	8,46	160	13,2	180	14,7	180	17,3	180
200	11,0	120	20,0	180	26,9	200	31,7	200
	8,46	160	14,9	200	16,5	200	19,5	200
220	11,0	120	20,0	180	29,9	220	35,4	220
	8,46	160	15,4	220	18,4	220	21,8	220
240	11,0	120	20,0	180	32,0	240	39,0	240
	8,46	160	15,4	220	20,3	240	24,0	240
260	11,0	120	20,0	180	32,0	240	39,9	260
	8,46	160	15,4	220	22,1	260	24,6	260
280	11,0	120	20,0	180	32,0	240	43,6	280
	8,46	160	15,4	220	24,0	280	26,8	280
300	11,0	120	20,0	180	32,0	240	45,0	300
	8,46	160	15,4	220	24,6	300	29,0	300
320	11,0	120	20,0	180	32,0	240	45,0	300
	8,46	160	15,4	220	24,6	300	29,0	300
340	11,0	120	20,0	180	32,0	240	45,0	300
	8,46	160	15,4	220	24,6	300	29,0	300
360	11,0	120	20,0	180	32,0	240	45,0	300
	8,46	160	15,4	220	24,6	300	29,0	300
380	11,0	120	20,0	180	32,0	240	45,0	300
	8,46	160	15,4	220	24,6	300	34,6	380

$F_{ax,R}$ kN	l_{min} mm
	$F_{ax,Rk}$
	$F_{ax,Rd}$

General information

ASSY screws are to be pre-drilled for hardwood or Beechwood laminated veneer lumber per ETA-11/0190 Table 1.

\varnothing	Pre-drilling \varnothing
5 mm	3,5 mm
6 mm	4 mm
7 mm	5 mm
8 mm	6 mm
10 mm	7 mm
12 mm	8 mm
14 mm	9 mm

Calculation base

- ETA-11/0190
- EN 1995-1-1:2010-12

The exceptions listed in key chapter must be taken into consideration.

NOTE: These represent planning aids. The values are to be measured by authorized persons for a specific project.

WITHDRAWAL CAPACITY HARDWOOD/BEECHWOOD LVL/STEEL-WOOD

$\alpha_2 = 0^\circ$ ASSY 3.0 + ASSY 3.0 ZINI

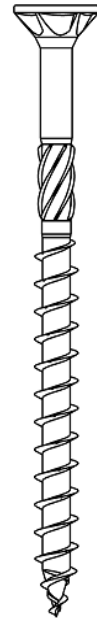
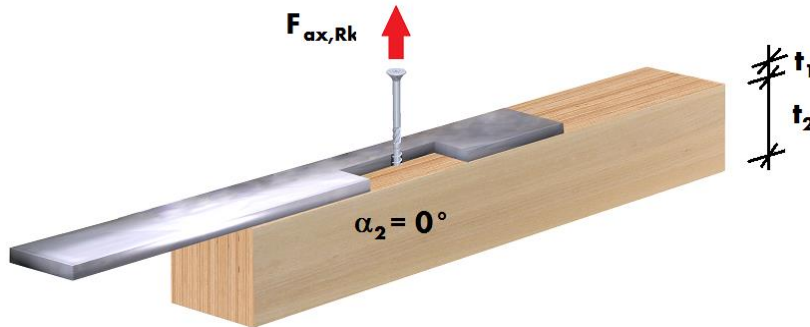

ASSY 3.0 - Withdrawal capacity $F_{ax,Rk}$ and $F_{ax,Rd}$ ($k_{mod} = 0,8$) with required minimum screw length l_{min}

t_2 mm	Ø 5mm $t_s = 5mm$		Ø 6mm $t_s = 6mm$		Ø 7mm $t_s = 7mm$		Ø 8mm $t_s = 8mm$		Ø 10mm $t_s = 10mm$	
	$F_{ax,R}$ kN	$F_{ax,R}$ mm	$F_{ax,R}$ kN	l_{min} mm	$F_{ax,R}$ kN	l_{min} mm	$F_{ax,R}$ kN	l_{min} mm	$F_{ax,R}$ kN	l_{min} mm
80										
100										
120										
140										
160			2,20	150						
180			1,35	150	3,12	180				
200			1,35	150	1,92	180	3,21	200		
220			2,20	150	3,12	180	4,01	220		
240			1,35	150	1,92	180	2,47	220		
260			2,20	150	3,12	180	4,01	220	4,56	260
280			1,35	150	1,92	180	2,47	220	2,80	260
300			2,20	150	3,12	180	4,01	220	4,56	260
320			1,35	150	1,92	180	2,47	220	2,80	260
340			2,20	150	3,12	180	4,01	220	5,47	320
360			1,35	150	1,92	180	2,47	220	3,36	320
380			2,20	150	3,12	180	4,01	220	5,47	320
400			1,35	150	1,92	180	2,47	220	3,36	320
420			2,20	150	3,12	180	4,01	220	5,47	320
			1,35	150	1,92	180	2,47	220	3,36	320

$F_{ax,R}$ kN	l_{min} mm
	$F_{ax,Rk}$
	$F_{ax,Rd}$

General information

ASSY screws are to be pre-drilled for hardwood or Beechwood laminated veneer lumber per ETA-11/0190 Table 1.

Ø	Pre-drilling Ø
5 mm	3.5 mm
6 mm	4 mm
7 mm	5 mm
8 mm	6 mm
10 mm	7 mm
12 mm	8 mm
14 mm	9 mm

Calculation base

- ETA-11/0190
- EN 1995-1-1:2010-12

The exceptions listed in key chapter must be taken into consideration.

NOTE: These represent planning aids. The values are to be measured by authorized persons for a specific project.

WITHDRAWAL CAPACITY HARDWOOD / BEECHWOOD LVL / STEEL-WOOD

$\alpha_2 = 0^\circ$ ASSY 3.0 COMBI

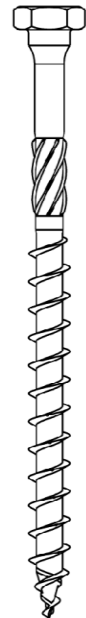
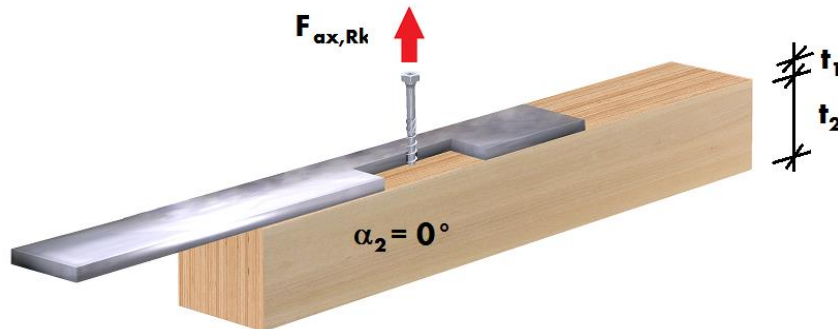

ASSY 3.0 Combi - Withdrawal capacity $F_{ax,Rk}$ and $F_{ax,Rd}$ ($k_{mod} = 0,8$) with required minimum screw length l_{min}

t_2 mm	\varnothing 8mm $t_s = 8mm$		\varnothing 10mm $t_s = 10mm$		\varnothing 12mm $t_s = 12mm$	
	$F_{ax,R}$ kN	l_{min} mm	$F_{ax,R}$ kN	l_{min} mm	$F_{ax,R}$ kN	l_{min} mm
80						
100						
120						
140						
160						
180						
200	3,21	200				
	1,97	200				
220	4,01	220				
	2,47	220				
240	4,01	220				
	2,47	220				
260	4,01	220	4,56	260		
	2,47	220	2,80	260		
280	4,01	220	4,56	260		
	2,47	220	2,80	260		
300	4,01	220	4,56	260	6,56	300
	2,47	220	2,80	260	4,04	300
320	4,01	220	5,47	320	6,56	300
	2,47	220	3,36	320	4,04	300
340	4,01	220	5,47	320	6,56	300
	2,47	220	3,36	320	4,04	300
360	4,01	220	5,47	320	6,56	300
	2,47	220	3,36	320	4,04	300
380	4,01	220	5,47	320	7,93	380
	2,47	220	3,36	320	4,88	380
400	4,01	220	5,47	320	7,93	380
	2,47	220	3,36	320	4,88	380
420	4,01	220	5,47	320	7,93	380
	2,47	220	3,36	320	4,88	380

$F_{ax,R}$ kN	l_{min} mm
	$F_{ax,Rk}$
	$F_{ax,Rd}$

General information

ASSY screws are to be pre-drilled for hardwood or Beechwood laminated veneer lumber per ETA-11/0190 Table 1.

\varnothing	Pre-drilling \varnothing
5 mm	3.5 mm
6 mm	4 mm
7 mm	5 mm
8 mm	6 mm
10 mm	7 mm
12 mm	8 mm
14 mm	9 mm

Calculation base

- ETA-11/0190
- EN 1995-1-1:2010-12

The exceptions listed in key chapter must be taken into consideration.

NOTE: These represent planning aids. The values are to be measured by authorized persons for a specific project.

WITHDRAWAL CAPACITY HARDWOOD / BEECHWOOD LVL / STEEL-WOOD

$\alpha_2 = 0^\circ$ ASSY PLUS VG COUNTERSUNK

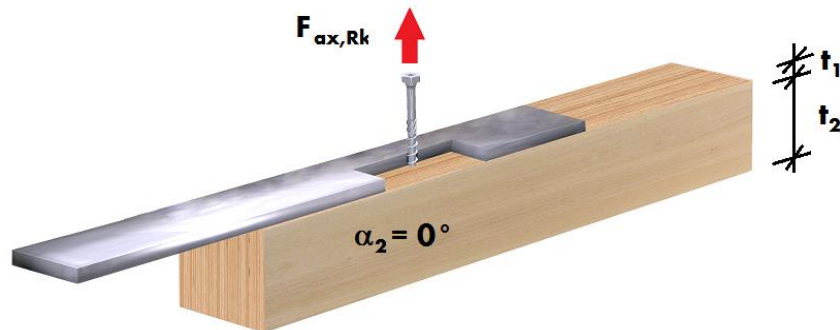

ASSY plus VG - Withdrawal capacity $F_{ax,Rk}$ and $F_{ax,Rd}$ ($k_{mod} = 0,8$) with required minimum screw length l_{min}

t_2 mm	$\varnothing 6\text{mm}$		$\varnothing 8\text{mm}$		$\varnothing 10\text{mm}$		$\varnothing 12\text{mm}$	
	$t_s = 6\text{mm}$		$t_s = 8\text{mm}$		$t_s = 10\text{mm}$		$t_s = 12\text{mm}$	
	$F_{ax,R}$ kN	l_{min} mm	$F_{ax,R}$ kN	l_{min} mm	$F_{ax,R}$ kN	l_{min} mm	$F_{ax,R}$ kN	l_{min} mm
120								
160	4,50	160						
	2,77	160						
200	5,75	200	7,26	200				
	3,54	200	4,47	200				
250	7,01	240	8,86	240	10,8	260		
	4,31	240	5,45	240	6,64	260		
300	7,64	260	11,0	300	12,4	300	14,2	300
	4,70	260	6,78	300	7,63	300	8,71	300
350	7,64	260	12,2	330	15,1	360	14,2	300
	4,70	260	7,52	330	9,31	360	8,71	300
400	7,64	260	14,2	380	16,9	400	18,5	380
	4,70	260	8,76	380	10,4	400	11,4	380
450	7,64	260	16,2	430	18,3	430	18,5	380
	4,70	260	9,99	430	11,3	430	11,4	380
500	7,64	260	17,8	480	20,1	480	24,0	480
	4,70	260	11,0	480	12,4	480	14,8	480
550	7,64	260	19,8	530	22,4	530	24,0	480
	4,70	260	12,2	530	13,8	530	14,8	480
600	7,64	260	20,0	580	25,6	600	30,6	600
	4,70	260	13,4	580	15,8	600	18,8	600
650	7,64	260	20,0	580	27,9	650	30,6	600
	4,70	260	13,4	580	17,2	650	18,8	600
700	7,64	260	20,0	580	30,2	700	30,6	600
	4,70	260	13,4	580	18,6	700	18,8	600
750	7,64	260	20,0	580	32,0	750	30,6	600
	4,70	260	13,4	580	20,0	750	18,8	600
800	7,64	260	20,0	580	32,0	750	30,6	600
	4,70	260	13,4	580	21,4	800	18,8	600

$F_{ax,R}$ kN	l_{min} mm
	$F_{ax,Rk}$
	$F_{ax,Rd}$

General information

ASSY screws are to be pre-drilled for hardwood or Beechwood laminated veneer lumber per ETA-11/0190 Table 1.

\varnothing	Pre-drilling \varnothing
5 mm	3.5 mm
6 mm	4 mm
7 mm	5 mm
8 mm	6 mm
10 mm	7 mm
12 mm	8 mm
14 mm	9 mm

Calculation base

- ETA-11/0190
- EN 1995-1-1:2010-12

The exceptions listed in key chapter must be taken into consideration.

NOTE: These represent planning aids. The values are to be measured by authorized persons for a specific project.

LAP SHEAR HARDWOOD/BEECHWOOD LAMINATED VENEER LUMBER/STEEL-WOOD

$\alpha_2 = 45^\circ$ ASSY PLUS VG COUNTERSUNK HEAD

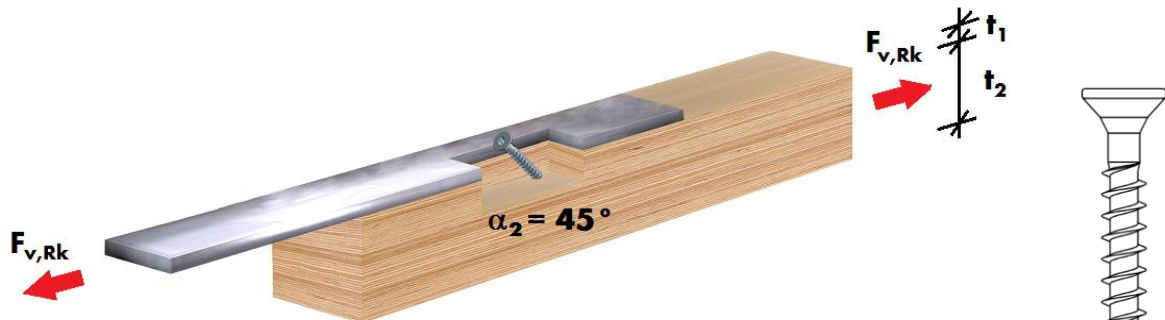

ASSY plus VG - Lap shear capacity $F_{v,Rk}$ and $F_{v,Rd}$ ($k_{mod} = 0,8$ and $\gamma_M = 1,3$) with required minimum screw length l_{min}

t_2 mm	$\varnothing 6\text{mm}$		$\varnothing 8\text{mm}$		$\varnothing 10\text{mm}$		$\varnothing 12\text{mm}$	
	$t_s = 12\text{mm}$		$t_s = 14\text{mm}$		$t_s = 18\text{mm}$		$t_s = 20\text{mm}$	
	$F_{v,R}$ kN	l_{min} mm	$F_{v,R}$ kN	l_{min} mm	$F_{v,R}$ kN	l_{min} mm	$F_{v,R}$ kN	l_{min} mm
60	5,11	80						
	3,15	80						
80	7,78	120	10,18	120	11,2	120	13,27	120
	4,97	120	6,26	120	6,91	120	8,16	120
100	7,78	120	12,07	140	13,4	140	15,84	140
	5,88	140	7,43	140	8,23	140	9,75	140
120	7,78	120	14,14	180	17,7	180	21,00	180
	5,98	160	9,75	180	10,9	180	12,92	180
140	7,78	120	14,14	180	19,8	200	23,58	200
	5,98	160	10,88	200	12,2	200	14,51	200
160	7,78	120	14,14	180	22,6	240	28,73	240
	5,98	160	10,88	200	14,8	240	17,68	240
180	7,78	120	14,14	180	22,6	240	31,31	260
	5,98	160	10,88	200	16,2	260	19,27	260
200	7,78	120	14,14	180	22,6	240	31,82	280
	5,98	160	10,88	200	17,4	280	20,85	280
220	7,78	120	14,14	180	22,6	240	31,82	280
	5,98	160	10,88	200	17,4	280	22,44	300
240	7,78	120	14,14	180	22,6	240	31,82	280
	5,98	160	10,88	200	17,4	280	22,44	300
260	7,78	120	14,14	180	22,6	240	31,82	280
	5,98	160	10,88	200	17,4	280	24,48	380
280	7,78	120	14,14	180	22,6	240	31,82	280
	5,98	160	10,88	200	17,4	280	24,48	380
300	7,78	120	14,14	180	22,6	240	31,82	280
	5,98	160	10,88	200	17,4	280	24,48	380
320	7,78	120	14,14	180	22,6	240	31,82	280
	5,98	160	10,88	200	17,4	280	24,48	380
340	7,78	120	14,14	180	22,6	240	31,82	280
	5,98	160	10,88	200	17,4	280	24,48	380
360	7,78	120	14,14	180	22,6	240	31,82	280
	5,98	160	10,88	200	17,4	280	24,48	380

$F_{v,R}$ kN	l_{min} mm
	$F_{v,Rk}$
	$F_{v,Rd}$

General information

ASSY screws are to be pre-drilled for hardwood or Beechwood laminated veneer lumber per ETA-11/0190 Table 1.

\varnothing	Pre-drilling \varnothing
5 mm	3,5 mm
6 mm	4 mm
7 mm	5 mm
8 mm	6 mm
10 mm	7 mm
12 mm	8 mm
14 mm	9 mm

Calculation base

- ETA-11/0190
- EN 1995-1-1:2010-12

NOTE: The value for shear capacity F_v can be multiplied by 1.25 if friction between the two components is to be estimated. In the case of connections using multiple screws, the effective number of screws n_{ef} per DIN EN 1995-1-1 (8.1.7) and/or ETA-11/0190 A.1.3.1 must be adhered to.

NOTE: These represent planning aids. The values are to be measured by authorized persons for a specific project.

LAP SHEAR HARDWOOD/BEECHWOOD LAMINATED VENEER LUMBER/STEEL-WOOD

$\alpha_2 = 45^\circ$ ASSY PLUS VG COUNTERSUNK + ANGLE PLATE

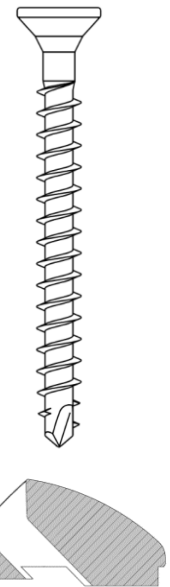

ASSY plus VG - Lap shear capacity $F_{v,Rk}$ and $F_{v,Rd}$ ($k_{mod} = 0,8$ and $\gamma_M = 1,3$) with required minimum screw length l_{min}

t ₂ mm	Ø 6mm		Ø 8mm		Ø 10mm		Ø 12mm	
	t _{S,min} = 3mm		t _{S,min} = 4mm		t _{S,min} = 5mm		t _{S,min} = 6mm	
	t _{S,max} = 6mm		t _{S,max} = 15mm		t _{S,max} = 21mm		t _{S,max} = 25mm	
	F _{v,R} kN	l _{min} mm	F _{v,R} kN	l _{min} mm	F _{v,R} kN	l _{min} mm	F _{v,R} kN	l _{min} mm
60	4,18	80						
	2,57	80						
80	7,14	120	8,13	120	7,87	120	8,36	120
	4,39	120	5,01	120	4,84	120	5,14	120
100	7,78	140	10,0	140	10,0	140	13,5	160
	5,31	140	6,17	140	6,17	140	8,31	160
120	7,78	140	13,8	180	14,3	180	16,1	180
	5,98	160	8,49	180	8,81	180	9,90	180
140	7,78	140	14,1	200	16,5	200	18,7	200
	5,98	160	9,66	200	10,1	200	11,5	200
160	7,78	140	14,1	200	20,8	240	23,8	240
	5,98	160	10,8	220	12,8	240	14,7	240
180	7,78	140	14,1	200	22,6	260	26,4	260
	5,98	160	10,9	240	14,1	260	16,2	260
200	7,78	140	14,1	200	22,6	260	31,5	300
	5,98	160	10,9	240	16,7	300	19,4	300
220	7,78	140	14,1	200	22,6	260	31,5	300
	5,98	160	10,9	240	17,4	320	19,4	300
240	7,78	140	14,1	200	22,6	260	31,5	300
	5,98	160	10,9	240	17,4	320	19,4	300
260	7,78	140	14,1	200	22,6	260	31,8	380
	5,98	160	10,9	240	17,4	320	24,5	380
280	7,78	140	14,1	200	22,6	260	31,8	380
	5,98	160	10,9	240	17,4	320	24,5	380
300	7,78	140	14,1	200	22,6	260	31,8	380
	5,98	160	10,9	240	17,4	320	24,5	380
320	7,78	140	14,1	200	22,6	260	31,8	380
	5,98	160	10,9	240	17,4	320	24,5	380
340	7,78	140	14,1	200	22,6	260	31,8	380
	5,98	160	10,9	240	17,4	320	24,5	380
360	7,78	140	14,1	200	22,6	260	31,8	380
	5,98	160	10,9	240	17,4	320	24,5	380

F _{v,R} kN	l _{min} mm
	F _{v,Rk}
	F _{v,Rd}

General information

ASSY screws are to be pre-drilled for hardwood or Beechwood laminated veneer lumber per ETA-11/0190 Table 1.

Ø	Pre-drilling Ø
5 mm	3,5 mm
6 mm	4 mm
7 mm	5 mm
8 mm	6 mm
10 mm	7 mm
12 mm	8 mm
14 mm	9 mm

Calculation base

- ETA-11/0190
- EN 1995-1-1:2010-12

NOTE: The value for shear capacity F_v can be multiplied by 1.25 if friction between the two components is to be estimated. In the case of connections using multiple screws, the effective number of screws n_{ef} per DIN EN 1995-1-1 (8.17) and/or ETA-11/0190 A.1.3.1 must be adhered to.

The exceptions listed in key chapter must be taken into consideration.

NOTE: These represent planning aids. The values are to be measured by authorized persons for a specific project.

ASSY® - THE SCREW FOR HARDWOOD OR BEECHWOOD LAMINATED VENEER LUMBER APPLICATIONS

Adolf Würth GmbH & Co.KG
D-74650 Künzelsau
T +049 7940 15-0
F +49 7940 15-1000
info@wuerth.com
www.wuerth.de

© by Adolf Wuerth GmbH & Co. KG
Printed in Germany
All rights reserved
Responsible for contents Dept. PCV Udo Cera,
Dept. P&A Herbert Streich

Reprints only by permission

We reserve the right to make changes to products that we believe result in a improvements to quality, including without announcement in advance or communication, at any time. Images may be sample illustrations that may vary from the appearance of products actually delivered. Errors are expressly reserved. We assume no liability for printing errors. Our Standard Business Terms apply.